

Univator

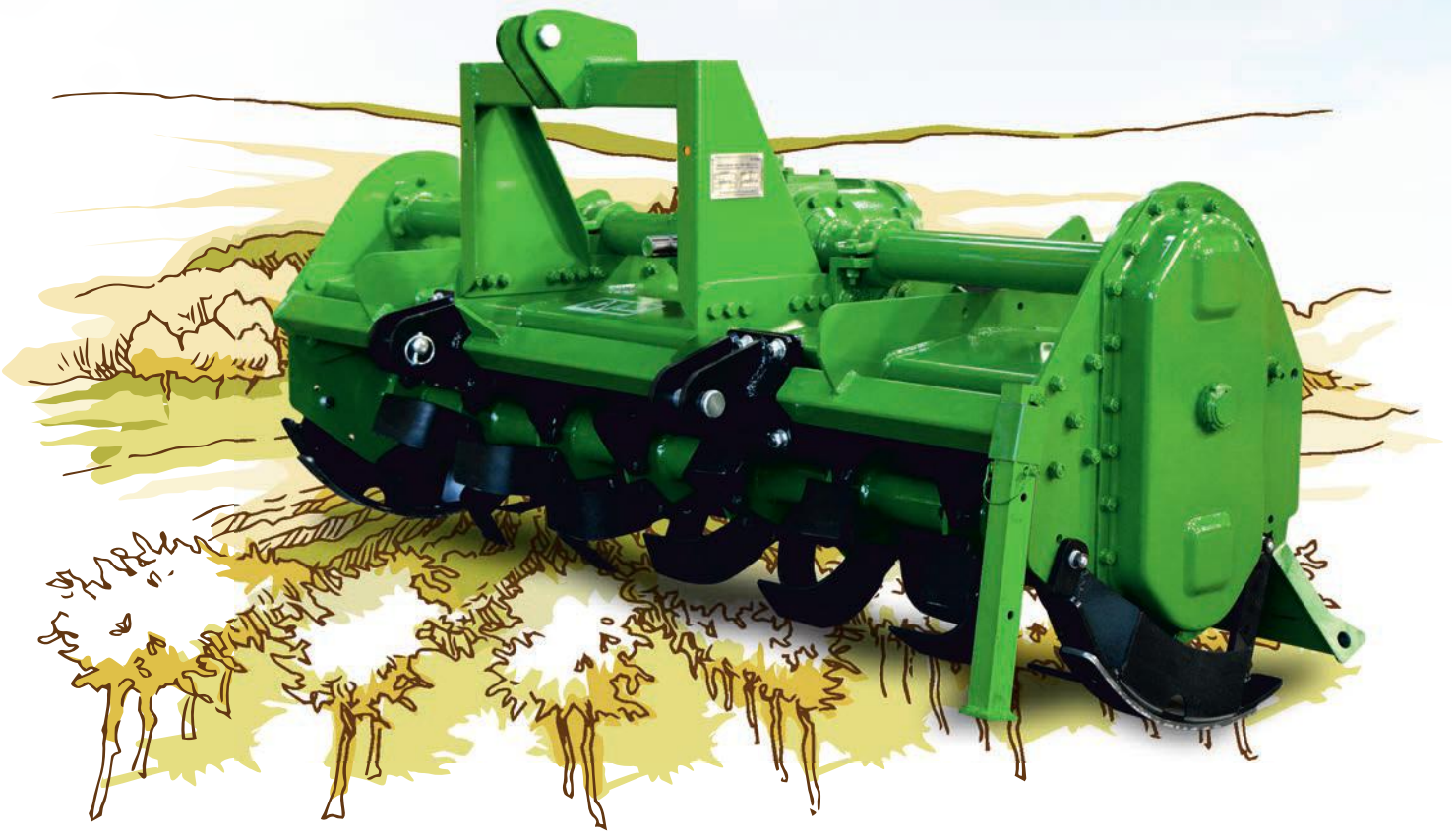

Operator and Service Manual

Cum Spare Parts Catalogue

FOREWORD

Congratulations!

We congratulate you for becoming a prestigious customer of Kirloskar Oil Engines Ltd. by purchasing UNIVATOR. This manual contains important information on Safety, Operation & Maintenance.

Please read it carefully and review it from time to time. Maintaining your UNIVATOR according to the schedule given in this manual to help you keep your UNIVATOR trouble free. This manual contains the use and maintenance instructions along with the list of the parts supplied as spares for the UNIVATOR.

This booklet also contains the warranty policy for UNIVATOR and its warranty registration card. The purchaser of this UNIVATOR shall read and understand all the terms and conditions mentioned under warranty and sign the warranty registration card.

A very warm Welcome!!

“Mark bearing word 'KIRLOSKAR' in any form as a suffix or prefix is owned by Kirloskar Proprietary Ltd. and Kirloskar Oil Engines Ltd. is the Permitted User”

INDEX

Sr. No.	Description	Page No.
1.0	Univator Manual	
1.1	Identification	05
1.2	Machine Specification and rotor speed chart	06
1.3	Nomenclature	07
1.4	Warranty	08
2.0	Safety Notes	
2.1	Safety Regulations	11
2.2	Safety Instructions	11
2.3	Warning Signals	12
3.0	Operating Information	
3.1	Before Use	16
3.2	Connecting The Univator To The Tractor	16
3.3	Instructions for Assembling the Cardan Shaft	16
3.4	Cardan Shaft Adaption	17
3.5	Changing Rotor Speed	18
3.6	Adjustment of Working Depth	20
3.7	Adjustment of Rear Bonnet	20
4.0	Maintenance, Servicing & Repair	
4.1	Precautions	21
4.2	Lubrication	21
4.3	Daily Maintenance Check Points	21
4.4	Parking	22
4.5	Storage	22
5.0	Troubleshooting	23
6.0	Spare Parts Catalogue	
6.1	Univator Assembly: KMW H Series	25
6.2	Gear Box Assembly KMW H Series	31
6.3	Univator Assembly: KMW L Series	34
6.4	Gear Box Assembly KMW L Series	39
6.5	Cardan Shaft Assembly	42
6.6	Coulter Wheel Assembly	44
7.0	Warranty Registration Card (WRC)	46
8.0	Pre Delivery Inspection Card	47
9.0	Installation Worksheet	49
10.0	Notes	51

1.1 IDENTIFICATION

Each individual machine has an identification plate indicating the following details:

- 1) Generic Name of Product
- 2) Application Code & Serial number combination
- 3) Model of Product
- 4) Gross Weight (Kgs.)
- 5) Minimum Prime Mover Power (HP)
- 6) Month/Year of Manufacturing
- 7) Name of Company
- 8) Manufactured By

You are advised to note down your data, along with the date of purchase and original Invoice, warranty coupon, in Safe Place and communicate these in case you need any service related help or resolution to query.

ROTARY TILLER		 Enriching Lives
CHASSIS NUMBER	MODEL / SIZE (DIA. OF ROTOR X WIDTH OF CUT)	
<input type="text"/>	<input type="text"/>	
WEIGHT / PRIME MOVER PTO SPEED / POWER	MONTH / YEAR OF MANUFACTURE	
<input type="text"/>	<input type="text"/>	
KIRLOSKAR OIL ENGINES LTD. A Kirloskar Group Company		
MADE IN INDIA		
<small>"Mark bearing word 'Kirloskar' in any form as a suffix or prefix is owned by Kirloskar Proprietary Ltd. and 'Kirloskar Oil Engines Ltd.' is the Permitted User." NAME & ADDRESS OF MANUFACTURER - JLPL (MS.)</small>		



1.2 MACHINE SPECIFICATION

Basic Specifications*							
Univator Model	Cutting Width	Length (mm)	Width (mm)	Height (mm)	Weight (Kg)	Blades (Nos)	Power (HP)
KMW 1500 L	1516	1650	990	980	355*	36	40+
KMW 1600 L	1616	1769	837	950	364	36	40+
KMW 1800 L	1816	1969	830	950	387	42	45+
KMW 1500 H	1516	1650	990	980	380	36	40+
KMW 1600 H	1616	1777	837	963	385	36	40+
KMW 1800 H	1816	1969	830	950	424	42	45+
KMW 2100 H	2116	2268	836	956	470	48	55+

Note - All models of Univator can be used for tractor PTO RPM of 540/1000. Customer should indicate the PTO RPM of the Tractor, for Selection of rotor speed through change gears in Gearbox. Indicated weight of machine may vary by +/- 5 %.

*In view of our policy of continuous improvement, we reserve the right to alter specification or design without prior notice and without liability. The features shown do not necessarily show the machine / equipment in its standard form. (E & OE)

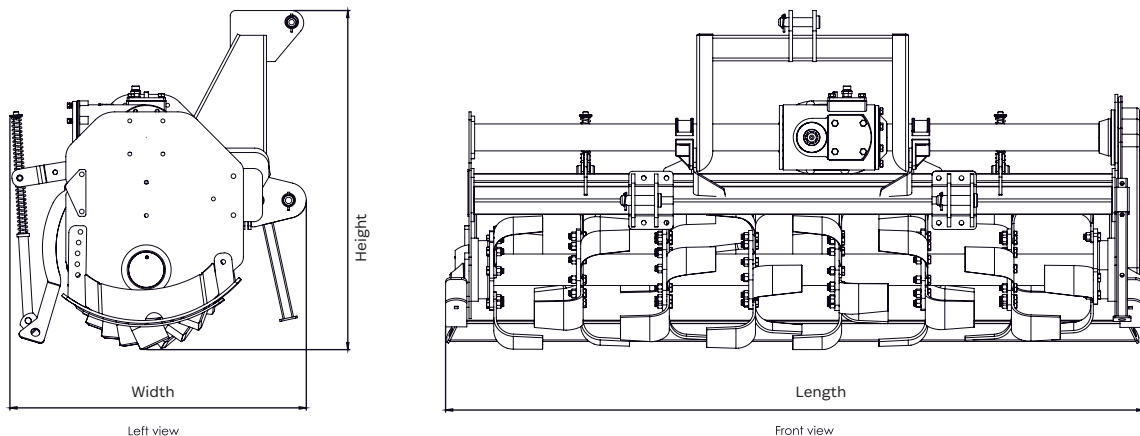
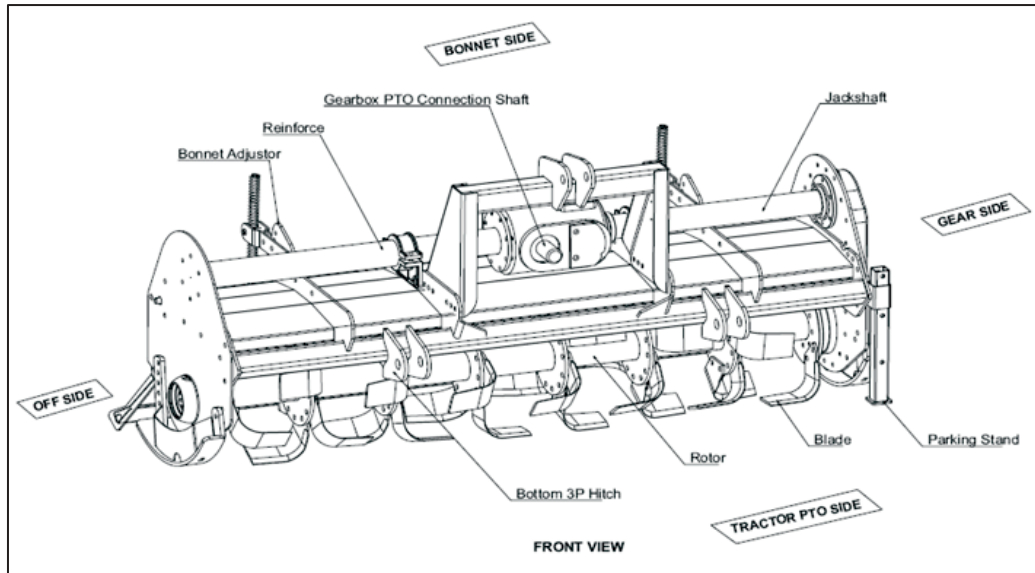
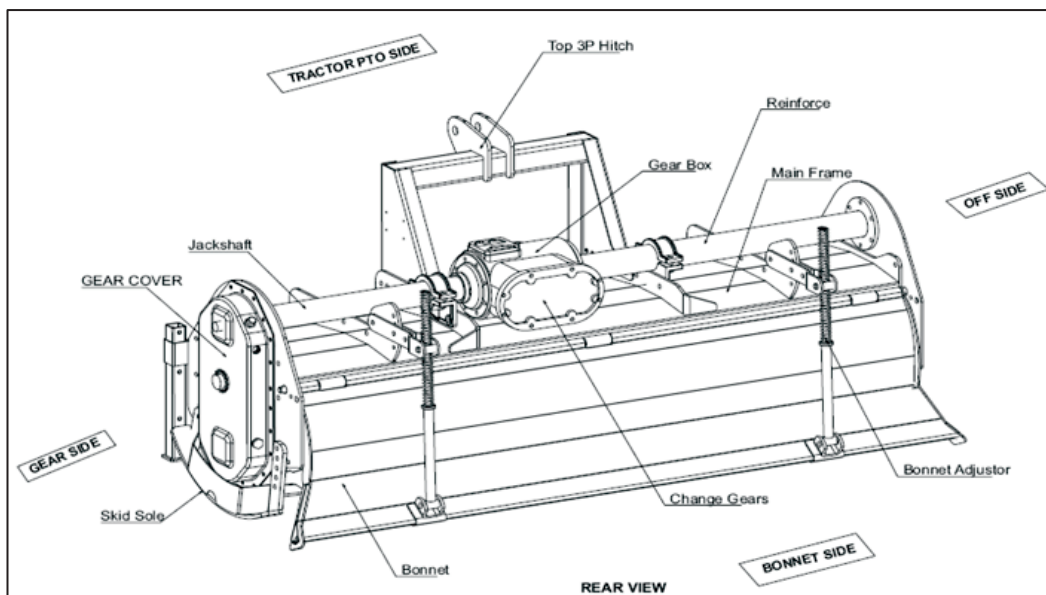

Image: A

1.3 NOMENCLATURE



Univator Front Side



Univator Rear Side

1.4 WARRANTY

1. Kirloskar Oil Engines Ltd., warrants to the retail purchaser of the Univator that subject to the limitation specified here in below, the Company's Authorized dealer will repair or replace any part thereof found, in its opinion, to be defective in materials or workmanship. The warranty shall be for a period 12 months from the date of purchase of New Univator by the original retail purchaser ("retail purchaser"). Duly filled warranty registration card is mandatory and must be submitted to KOEL.
2. This warranty is limited to the delivery to the retail purchaser, free at the Authorized Dealer's workshop or Company's works, of the part or parts whether repaired or replace in exchange for those acknowledge by the Company to be defective.
3. The purchaser of Univator are advised strictly to follow the instructions given in the operator manual, provided by the company along with the Univator at the time of delivery. Changes if any in the machine, resulting in improper usage will not be covered by the warranty. This warranty will automatically get terminated on the expiry of warranty period even if the machine may not be in use for any time during the warranty period for any reason whatsoever including any technical reasons, and, time taken for such repairs / replacements of parts and in transit, whether under this warranty or otherwise shall not be excluded from the warranty period.
4. This warranty shall not apply to the following:
 - Wear Items like Blades, Skid etc.
 - Cardan Shaft and Universal cross joints
 - Bearing
 - Rubber parts/ Gaskets
 - Fasteners
 - Lubricants
5. The retail purchaser shall be required to make a thorough examination of the Products prior to the purchase. The Authorized Dealer are in no way the legal agent of the Company and have no right or Authority to give any warranty or assume any obligation on behalf of the Company or bind the Company in any manner whatsoever.
6. For the purpose of this warranty, the term "product" means and includes only new Univator, manufactured by or for the Company to the Company's design and drawing and sold and installed by the Authorized Dealer.
7. The Company's responsibility is limited to the terms of this Warranty and it shall not be liable for personal injuries or consequential or resulting liability, damage or loss arising from any defect.
8. The Company's Liability under this Warranty is dependent upon the strict observance by the retail Purchaser, of the following provisions
 - The Retail purchase at the time of delivery shall sign, complete and return the Authorized Warranty and Dealer's Delivery Report form.
 - All the parameters should be thoroughly checked as per the scheduled maintenance as mentioned in the operator manual. The customers are also bound to use the genuine spares for machine purchased from authorized dealers.
 - Repair or replacements will be performed by the facility of the Authorized Dealer/its branch dealer/its Authorized Service Center only, following delivery of the Product by the retail surcharge to the facility of the Authorized Dealer/its branch dealer/its Authorized Service Center.
 - This Warranty shall not apply if the Product or any part thereof repaired or altered not in accordance with our standard repair procedure or by any person other than an Authorized Dealer/its branch dealer/its Authorized Service Centre.













- The Retail Purchaser shall at all times use only those brands of lubricating oils, lubricants or fuel which are approved in writing by the Company, for operating the products.
 - The decision of the Company or the concerned Authorized Dealer in regard to the warranty shall be final and conclusive and the retail Purchaser hereby agrees to unconditionally accept their decision on all.
 - This warranty does not cover any applicable taxes payable on any parts which the company may supply or repairs free of cost of during the warranty period. This warranty also does not cover the cost of packaging to and fro freight and transportation charges etc. on the defective machine or other parts of the machine sent to Dealers locations
 - Claims arising from this warranty will be considered only if they are notified in writing to the concerned Authorized Dealer or to the Company promptly after the defect has been ascertained.
 - The Company reserves the right to make changes in design or introduce any improvement or add any parts on the Products at any time without incurring any obligation to install the same on Products previously sold.
9. This contract will be ineffective and incorporative if:
- The duly filled warranty card is not presented during the repairs.
 - The Univator or any parts thereof is subjected to neglect, fire, floods or other acts of God or if in the company's opinion any damage has caused to the Univator during transportation.
 - The original numbers are removed, obliterated or altered from the unit.
 - Any attempt is made to have the repairs executed by a person, other than the company's or its authorized representatives.
 - Any defect is not informed immediately to the company or its authorized representative, any alterations in the warranty card is made.
 - The use of replacement parts not manufactured or supplied by the company will automatically invalidate this warranty.
 - This warranty shall not apply to defect/damages caused by normal wear and tear, accident, transportation, misuse or neglect, usage in non agric applications, defect in the products which have been altered outside the Company's work or which have been let out on hire or the identification marks on which have been altered or removed. Company's decision in this respect will be final and binding on all.
10. The warranty will become void when:
- Besides the cases specified in the supply agreement, the warranty shall in any case become void.
 - Should there have been a manoeuvring error, use of an inadequate safety bolt on the Cardan shaft or when the Cardan shaft has been damaged through improper maintenance.
 - When the implement has been used beyond the specific power limit as given in the technical data chart.
 - When the defects gets arise due to the machine operations in conjunction with unauthorized attachments.
 - When following repairs made by the customer without authorization from the manufacturer or owing to installation of spurious spare parts, the machine is subject to variations and the damage can be ascribed to these variations.
 - Whenever the user or anyone else on his behalf applies equipment to the machine that has not been expressly approved by the manufacturer.

- When the user failed to comply with the instructions in this operator's manual
 - The warranty is non-transferable and is valid for first retail purchaser of the product. In case the product is sold by first retail customer to another person the warranty becomes void and Null
11. The above Warranty is in lieu of all other Warranties express or implied, and no person, agent or representative of the Company is authorized to give any other warranties on the Company's behalf or to assume for it any other liability in connection, with the Product.
 12. The court at Pune shall have exclusive jurisdiction to try, entertain and dispose of all proceeding relating to any dispute arising between the Company and the retail purchaser on the liability of the Company under this warranty.

2.1 SAFETY REGULATIONS

- 2.1.1 A licensed driver should operate the machine
- 2.1.2 If any trouble occurs due to overload or sudden resistance (large stones), stop the tractor immediately and take out the Cardan shaft. Lift the Univator, detect the cause and remove the solid bodies. Be sure, there is no damage in working parts and continue the work.
- 2.1.3 The angle formed by the P.T.O. shaft centreline and the centreline of the Cardan axle should never exceed 30 Degree.
- 2.1.4 All servicing and maintenance operations must be performed only at rest, with tractor switched off.
- 2.1.5 Do not try to take turns with the blades in contact with the ground. Before turning, lift the Univator in transport position.
- 2.1.6 Do not get under the machine when it is in transport position.
- 2.1.7 Do not operate the machine or allow anyone to come near machine when under influence of intoxicants like alcohol etc.

2.2 SAFETY INSTRUCTIONS

<p>Read the Operation & Maintenance manual Before using the machine</p> 	<p>Danger to hand and fingers due to collision with parts in rotation. Keep the safe distance</p> 
<p>Danger to feet due to Collision with parts in Rotation. Keep the safe distance</p> 	<p>Danger to feet due to rotating cutters. Keep the safe distance</p> 
<p>Danger due to machine Component that is Lifted above the ground. Keep the safe distance</p> 	<p>Danger of cutting due to moving parts. Wait until all moving components are completely motionless before approaching the machine.</p> 
<p>Danger due to flying objects. Keep the safe distance</p> 	<p>Danger to hot surface. Keep the safety Distance</p> 
<p>Danger of hand and finger cutting. Keep the safe distance.</p> 	<p>Danger of feet cutting Maintain the safety distance</p> 
<p>Danger of rotating movements. Do not open or remove the safetyguards of the rotating shafts while the machine is</p> 	<p>Danger due to loads lifted from the ground. Keep the safety distance</p> 

2.3 WARNING SIGNALS

2.3.1 There are three types of signals:

DANGER:

This signal warns when serious injuries, death or long-term health risks would be caused by failure to correctly carry out the described operations.

WARNING:

This signal warns when serious injuries, death or long-term health risks could be caused by failure to correctly carry out the described operations.

CAUTION:

This signal warns when damage to the machine could be caused by failure to carry out the described operations.

2.3.2 In order to identify the various levels of danger, the following describe situations and specific definitions that may directly involve the machine or persons.

DANGER ZONE:

Any area inside and / or near a machine in which the presence of an exposed person constitutes a risk for the safety and health of that person.

EXPOSED PERSON:

Any individual who happens to be completely or partly in a risk zone.

OPERATOR:

The person/s charged with installing, starting up, adjusting, carrying out maintenance, cleaning, repairing or transporting a machine.

USER:

The user is the person or the organization or the firm which has purchased or rented the machine and intends to use it for the purposes it was conceived for.

SPECIALIZED PERSONNEL:

Those persons who have been specially trained and qualified to carry out interventions of maintenance or repair requiring a particular knowledge of the machine, its functioning, safety measures, methods of intervention - and who are in a position to recognize the potential dangers when using the machine and are able to avoid them.

AUTHORIZED SERVICE CENTER:

The authorized Service Center is a structure legally authorized by the manufacturer which disposes of personnel specialized and qualified to carry out all the operations of assistance, maintenance and repair - even of a certain complexity - found necessary to keep the machine in perfect working order

Become thoroughly familiar with all the instructions before using the machine. Contact the dealer in case of doubt. The Manufacturer declines all and every responsibility for failure to comply with the safety and accident prevention. Regulations described herein.

- 1) Comply with the instructions given by the danger symbols in this handbook and affixed to the machine itself.
- 2) Never ever touch any moving part.
- 3) Operations and adjustments to the implement must always be carried out when the engine is off and the tractor braked.
- 4) Before proceeding with any work under the machine, make sure that the driveline has been detached from the PTO and secure the machine itself with supports to make sure that it is unable to accidentally drop.
- 5) It is absolutely forbidden for persons without a driving license, in expert persons or those in precarious health conditions to drive the tractor with the machine mounted.

- 6) Strictly comply with all the recommended accident preventing measures described in this booklet.
- 7) Assembly of an implement on the tractor will shift the weights on the axles. It is therefore advisable to add weights to the front part of the tractor in order to balance the weights on the axles themselves.
- 8) The coupled implement may only be controlled through the Cardan shaft complete with the necessary safety devices for overloads and with the guards fixed with the relative latch. Keep away from the Cardan shaft while it is turning.
- 9) Before starting the tractor and implement, always check that all safety devices, guarding transports and use are in a perfect condition.
- 10) The instruction labels affixed to the machine give useful advice on how to prevent accidents.
- 11) Always comply with the Highway Code in force in your country when traveling on public roads.
- 12) Transport on roads takes place under the total responsibility of the user, who is obliged to verify the adequacy of the machine to the rules of the road traffic code in force in that country.
- 13) Comply with the maximum permissible weight on the axle of the tractor, the total adjustable weight, shipping regulations and the Highway Code.
- 14) Always become familiar with the controls and their operation before starting work.
- 15) Always wear suitable clothing. Never ever wear loose garments or those with edges that could in some way become caught up in rotating components or moving mechanisms.
- 16) As indicated, couple the implement to a tractor of equal power and configuration, applying a device (lift), confirming to the prescriptions.
- 17) Take the utmost care during the implement coupling and release phases.
- 18) Any accessories for transport must be equipped with adequate signals and guards.
- 19) Never ever leave the driving seat while the tractor is moving.
- 20) It is very important to remember that the road holding, steering and braking capacity may be even notably influenced by the presence of a towed or mounted implement.
- 21) Always take care of the centrifugal force exercised by the furthered position of the center of gravity, when turning corners with the implement mounted.

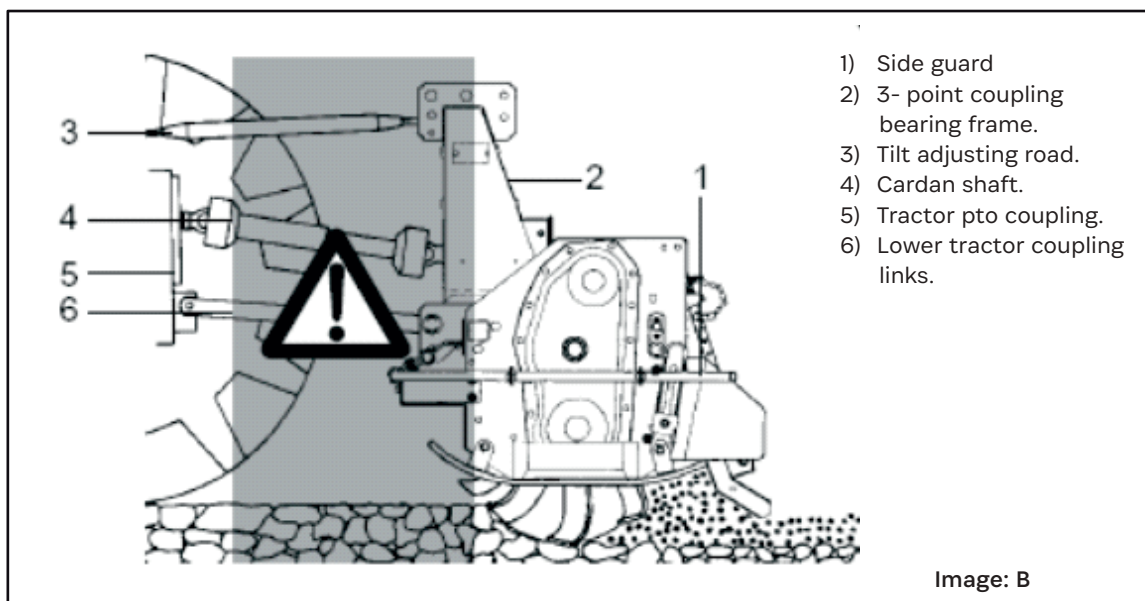

- 22) Before engaging the PTO, check that the RPM rate is that prescribed. Never exchange the 540 RPM rate for 1000 RPM. It is absolutely forbidden to stand within the operative range of the machine where there are moving parts.
- 23) Before leaving the tractor, lower the implement coupled to the lift unit, stop the engine, engage the hand brake and remove the ignition key from the control panel.
- 24) It is absolutely forbidden to stand between the tractor and the machine (Image: B) when the engine is running and the Cardan shaft is engaged without having first engaged the hand brake. Keep a safe distance from the machine at work to avoid being hit by possible flying stones, etc.
- 25) Always set the lift control lever to the locked position before coupling or releasing the implement from the three-point coupling.
- 26) The category of the implement coupling pins must correspond to that of the lift coupling.
- 27) Take care when working near the lift links. Beware, it's a very dangerous zone.
- 28) It is absolutely forbidden to stand between the tractor and the implement when maneuvering the lift control from the outside (Fig. 1)
- 29) Fix the side lift links with the relative chains and idlers during the transport phase.
- 30) Set the control lever of the hydraulic lift to the locked position during road transport with the implement raised. When hoisting from the ground, the joints of the Cardan shaft are bent to more than 40° (power takeoff turned off). Detach the shaft from the power takeoff of the tractor.
- 31) Only use the Cardan shaft recommended by the Manufacturer.
- 32) Frequently and periodically check the Cardan shaft guard. It must constantly be in an excellent condition and well-welded.
- 33) Take great care of the Cardan shaft guard, both in the transport and work positions.
- 34) The Cardan shaft must only be installed or dismantled while the engine is off.
- 35) Take great care to ensure that the Cardan shaft is correctly assembled and safe, and carefully check the locking, both on the P.T.O. of the machine and on the P.T.O. of the tractor.
- 36) Use the supplied latch to prevent the Cardan shaft guard from turning both on the machine's and on the tractor's side.
- 37) Before engaging the P.T.O., ensure that there are no persons or animals in the field of action of the machine and that the selected running rate corresponds to the permissible value. Never exceed the recommended maximum rate.
- 38) Never engage the P.T.O. when the engine is off.
- 39) Always disengage the P.T.O. when the Cardan shaft is set at an excessively open angle (never beyond 30 degree – Image: C) and when it is not in use.

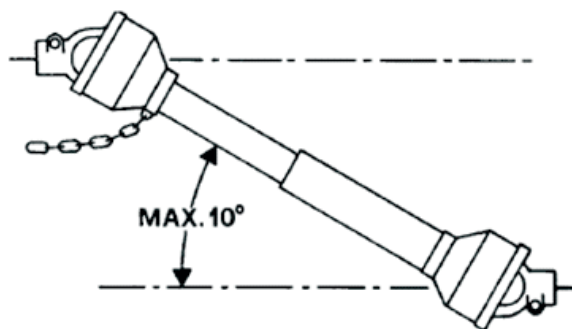

Fig. 2

Image: C

- 40) Only clean and grease the Cardan shaft when the P.T.O. is disengaged, the engine off, the hand brake engaged and the ignition key removed.
- 41) Rest the Cardan shaft on its stand when the machine is disconnected.
- 42) Refit the protective cap on the P.T.O. shaft after having dismantled the Cardan shaft.
- 43) Lengthy use of the machine can, as a secondary effect, overheat the overdrive and parts of the hydraulic circuit. Never touch these parts immediately after use as they are very hot and can cause burns.
- 44) Never carry out maintenance or cleaning work unless the P.T.O. has been disengaged, the engine switched off, the hand brake engaged. Periodically check the state and condition of the protective bars and the protection flap bar.
- 45) Periodically check that all nuts and bolts are fully fastened. Re-fasten them if necessary.
- 46) Always place adequate supports under the implement when servicing the machine or replacing the hoe blades with the implement raised.
- 47) Before working on the cutting tools, disengage the P.T.O., switch off the tractor engine, engage the hand brake and check that the blades are completely at a standstill.
- 48) Only use the recommended oil.
- 49) The spare parts must correspond to the requirements established by the manufacturer. Always use genuine spare parts.
- 50) The safety transfers must always be perfectly visible. They must be kept clean and should be replaced if they become illegible. Replacements are available on request from your local dealer.
- 51) The instruction manual delivered together with the machine by the dealer must be kept for as long as the machine lasts.



- 52) In the event a tractor is used that has no pressurized, soundproof cabin the operator must use individual methods of protection
- 53) Protective headphones for noise in case the standard levels of exposure are exceeded. Anti-dust mask, if a considerable quantity of dust is raised caused by the type of product cut, by very dusty earth, or by the usage of an open machine.

3.1 BEFORE USE: BEFORE STARTING THE MACHINE, CHECK THAT

- 3.1.1 The machine is perfectly in order that the lubricants are at the correct levels (see «Maintenance» chapter) And that all parts subject to wear and deterioration are fully efficient.
- 3.1.2 Check the machine, correctly positioned for obtains the right working depth.

3.2 CONNECTING THE UNIVATOR TO THE TRACTOR

- 3.2.1 Univator can be applied to any type of tractor as long as it is supplied with 3P universal attachment.
- 3.2.2 The Univator must be positioned on a flat surface, in a stable position.
- 3.2.3 The tractor must reverse towards the Univator until its arms correspond to the arms of the 3P of Univator. During this phase, any pedestrian/onlooker must be at least 5 m from the machine.
- 3.2.4 Position the plugs of the lower 3 pins and lock them using the supplied lynch pins.
- 3.2.5 Connect the upper tractor arm to the upper pin of the 3P, adjusting it in a way that the machine takes a parallel position to the ground.

3.3 INSTRUCTIONS FOR ASSEMBLING THE CARDAN SHAFT

- 3.3.1 Before mounting the Cardan shaft, carefully read the booklet supplied by the Manufacturer.
- 3.3.2 Manufacturer declines all responsibility for operations carried out on the Cardan shaft if the specific Instructions supplied by the Manufacturer are not followed.
- 3.3.3 Position the Cardan shaft and check that its ends are well coupled with tractor's power take off (P.T.O.).
- 3.3.4 Fix the anti-rotation chains present on the drive shaft both on the Tractor side and on the Univator side. During this phase the tractor engine must be switched off, to prevent an incorrect manoeuvre from activating the Power take off (P.T.O.).
- 3.3.5 After having carried out above operations, it is possible to activate the tractor lifting device to release the support feet (if present), which must be completely raised and blocked using the supplied pins.

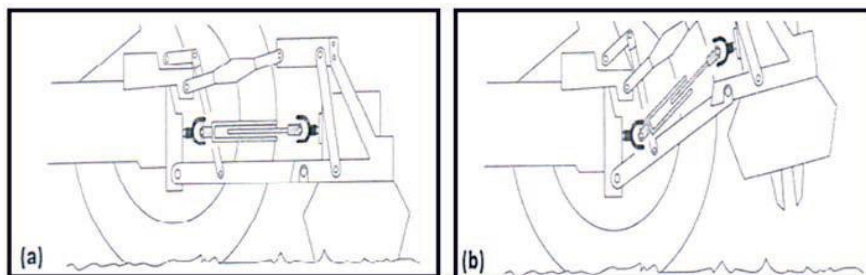

Image: D

- 3.3.6 If the land has masses, stones or anything else that may cause blows on the blades, the use of Cardan shaft With clutch or with other safety system (Shear Bolt Torque Limiter or Auto Torque Limiter LR) is Indispensable. It is also advised to run the tractor with lower speed, to soften blows on the machine.
- 3.3.7 Any problems caused by working on particularly rocky land will not be covered in the warranty.

3.3.8 The calibration of the Cardan joint clutch/Shear Bolt must also be checked to be sure that it carries out its function correctly. It is advised to carry out this control at a specialized centre. The clutches/Shear Bolts on the Cardan shaft normally supplied by KOEL are calibrated to the maximum available load. It is advised to have the Cardan shaft; Clutch/Shear Bolt checked by a specialist every 300 working hours or, if the work is seasonal, on re-starting activity after the break.

3.4 CARDAN SHAFT ADAPTION

3.4.1 The Cardan shaft, supplied with the machine is of standard length. Therefore, it might be necessary to adapt the Cardan shaft. In that case, before doing anything, consult the Manufacturer for the eventual adaptation. Hitch the machine to the tractor and stabilize the tractor's third point with the device set up for that purpose (bar, range, and so on).

3.4.2 Disengage the tractor's P.T.O. and turn off the engine. Connect the Driveline shaft to the tractor's P.T.O. The connection is correct when the machine is horizontal in the operating position. To achieve this, increase or decrease the length of the top bar of the hitch (B Image E) so as to set the axis (X Image: E) of the housing's grooved ring nut parallel to the ground.

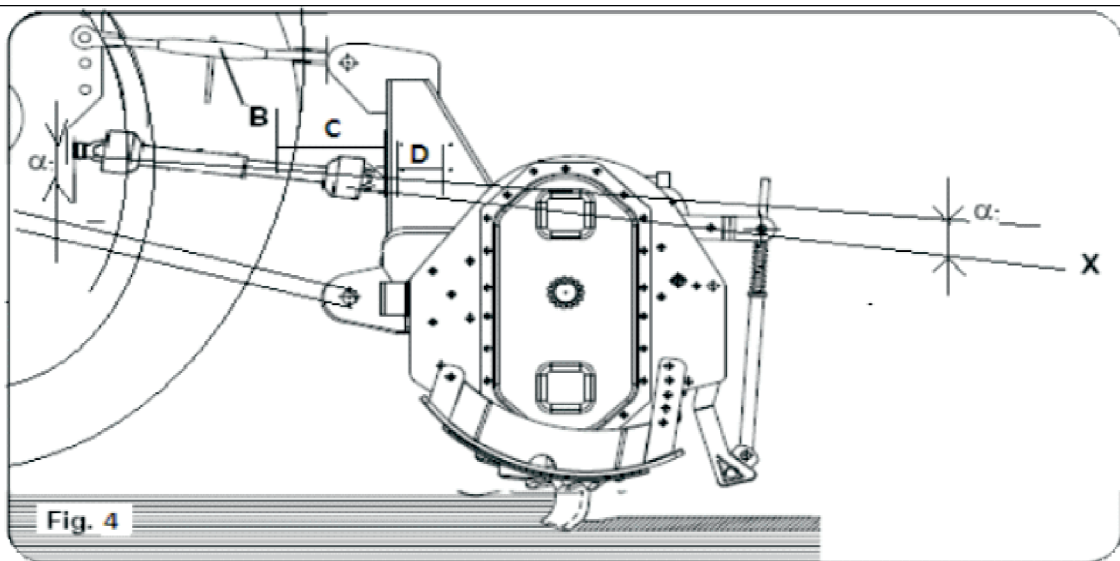

Fig. 4

Image: E

3.4.3 Inspections at work :

- The two angles (Fig. 4) formed by the fork axes and the axis of the sliding tubes will be equal and must not, exceed 10°
- The sliding tubes (C Fig. 4) must overlap by at least 15 cm (Fig. 5).

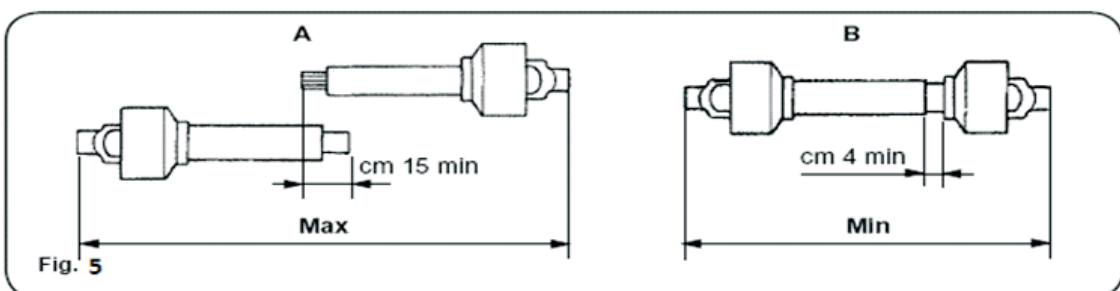

Fig. 5

3.4.4 Inspections in the raised position:

- Proceed with a lifting action (tractor P.T.O. disengaged).
- The two tubes of the drive line shaft must not fully overlap. There must always be a safety travel (D Fig.4) of at least 4 cm.
- The angles (Fig.4) of the drivelines must not exceed 40° (Fig. 4). If these two results are not obtained:
- Shorten the sliding tubes by the same extent (Fig. 6 and 7), deburr and trim (Fig. 8), then grease the inside of the outer tube (Fig. 9).
- Make sure that the upper hitch bar is as parallel as possible to the lower bars of the hitch.
- If this is not sufficient, correct the way the top link of the hitch couples to the tractor or machine, as necessary, or at least considerably attenuate the jolts to which the drive line shaft is subjected during the lifting phase.
- If errors have been committed, disengage the tractor's P.T.O. before lifting the machine. Repeat these inspections when the machine is hitched behind another tractor.



- When the Cardan shaft is fully extended, the two tubes must overlap by at least 15 cm. When fully inserted, the minimum play must be 4 cm. (Fig. 5).



If the implement is used on another tractor, always check that the guards completely cover the rotating parts of the Cardan shaft.

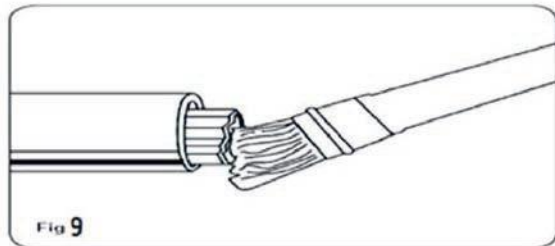
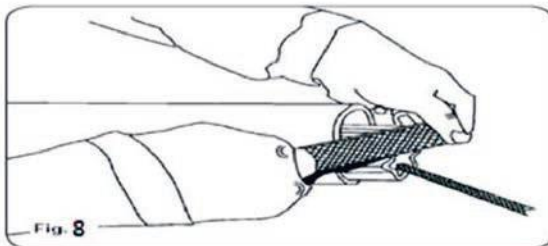
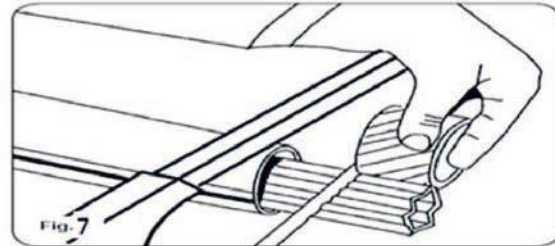
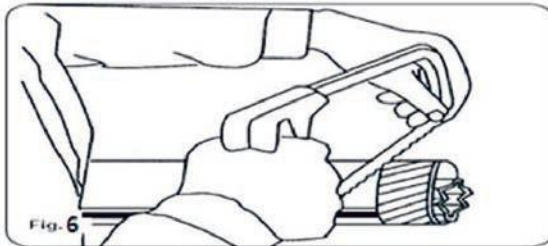

3.5 Changing Rotor Speed

The operations for gear replacement and changing the rotor speed are as follows:

- 3.5.1 Stop the tractor & rest the attached Univator on the flat surface, apply the tractor hand-brake

- 3.5.2 Disconnect the Cardan shaft joint from the tractor's power take off (P.T.O).
- 3.5.3 Wait for the Gearbox to cool before carrying out any operation. Cooling time depends on previous use of the Univator before stopping and also on atmospheric conditions.
- 3.5.4 After having ensured that the gearbox is cooled, rest the Univator in the inclined position with the use of parking stand. An inclined position is essential to avoid oil spillage from the gearbox.
- 3.5.5 Use a “Metric Ring/Flat Spanner” of size 12-13 (for M8 bolt) & “External Circlip Plier Straight Nose Type” of Size @ 200mm.
- 3.5.6 Remove the gearbox rear cover & take care that the gasket is not damaged.
- 3.5.7 Replace the gears mounted in the gearbox with the change gear set, refer the chart 10/11, if in doubt about the positioning of the gear, and contact the authorized dealer.
- 3.5.8 Shims are provided in the gearbox to align the faces of the change gears & also to restrict the axial displacement of the gears. Use the available shims & insert the circlip to achieve the above condition.
- 3.5.9 Replace the gasket if damaged. Remount the cover with the gasket, place the bolts with spring washers & tighten it properly.
- 3.5.10 Check the oil level with the 'Dipstick', if it is low, fill it with the recommended oil. Refer Table No. B for the recommended oil.

Rotor Speed Chart

Speed Chart for Univator Model: KMW 1500 H, KMW 1600 H, KMW 1800 H, KMW 2100 H										
	540 RPM Input PTO Tractor						1000 RPM Input PTO Tractor			
Change Gear Set >>	15-20**		16-19**		17-18*		13-22**	14-21**	15-20**	16-19**
Driving Gear 1	15	20	16	19	17	18	13	14	15	16
Driven Gear 2	20	15	19	16	18	17	22	21	20	19
Rotor Speed (RPM)	155	275	175	245	195	218*	226	255	286	322

Speed Chart for Univator Model: KMW 1500 L, KMW 1600 L, KMW 1800 L							
	540 RPM Input PTO Tractor				1000 RPM Input PTO Tractor		
Change Gear Set >>	16-20*		17-19**		14-22**	16-20**	17-19**
Driving Gear 1	16	20	17	19	14	16	17
Driven Gear 2	20	16	19	17	22	20	19
Rotor Speed (RPM)	144	226*	162	202	213	267	299

*Standard Supply / ** Optional to be Purchased at Extra Cost
 Warning: Use Only the Pair As per Table and do not use alternate combinations.

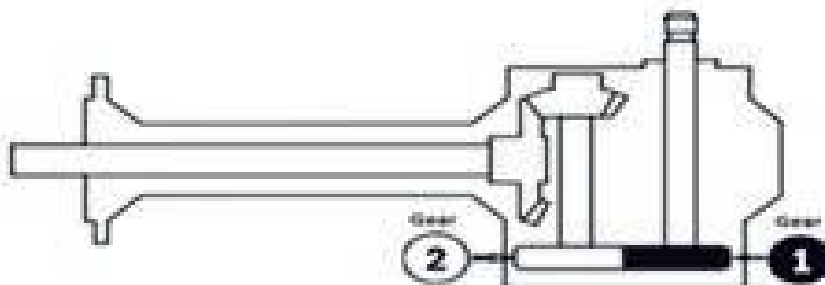
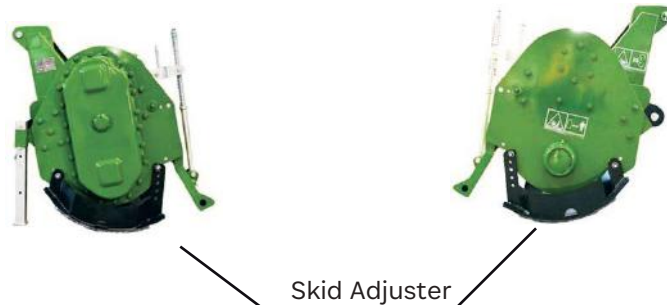

Image: F

3.6 ADJUSTMENT OF WORKING DEPTHS

Before using the Univator, it is necessary to adjust working depth.



Depending on the soil & tractor condition, the 'Skid' position should be adjusted by the 'Skid Adjustor'. Changing the skid position will affect the rear bonnet setting. Hence, with working depth adjustment, also adjust the rear bonnet. After adjustments/settings, ensure that all fasteners are properly fastened.

3.7 ADJUSTMENT OF REAR BONNET

It is possible to adjust the height of the rear bonnet by moving the arm of shock absorber in one or more positions. See Fig. B, for Bonnet Adjustor.

Depending on the soil & tractor condition, the position of rear bonnet, determines the quality of pulverization.

3.7.1 Dry lands :

To obtain the best breaking-up of the land and perfect levelling, the bonnet must be lowered and kept near to the rotor blades.

3.7.2 Damp, wet or clay land :

To prevent jamming, the bonnet must be raised and kept as far away as possible from the rotor blades

Adjustments should be made when the machine is stopped & tractor is switched off. Also ensure that the Cardan Shaft joint on tractor PTO is disconnected.

4.1. PRECAUTIONS BEFORE APPROACHING THE MACHINE, FOR ANY MAINTENANCE OR REPAIRS, IT IS COMPULSORY TO TAKE FOLLOWING PRECAUTIONS:



- 4.1.1. Stop the tractor on flat surface and rest the Univator on the flat surface.
- 4.1.2. Apply the tractor handbrake.
- 4.1.3. Turn off the engine and Disengage the Cardan shaft.
- 4.1.4. The maintenance /repair work should be carried out at a well-equipped workshop or by consulting the Dealer. In case of specific maintenance or repair where it is necessary to lift the machine from the ground or rotate it, it is indispensable to use suitable equipment (the machine weight is indicated in Table No. A).
- 4.1.5. Before start of any maintenance/repair works, wait for machine parts such as gearbox, bearings to cool.
- 4.1.6. The cooling time for these parts depends on the previous work carried out and external atmospheric conditions.
- 4.1.7. Any maintenance/repairs/replacement of component or assembly must be carried out or made by a trained person only. It is always recommended to use genuine spares.

4.2. LUBRICATION

- 4.2.1. Check the gearbox vent cap for any blockage. If found blocked, replace it with new

Item	Type of Lubricant	Period of Lubrication Change
Side Gears	API Multipurpose Grease	Change after every 330 Working Hours
Gearbox	SAE 80W90	Change after every 330 Working Hours
PTO & Bearings	API Multipurpose Grease	Lubricate after every 8 working Hours

Table No. B

Item	Type of Lubricant	Qty. (Ltr./Kg)
 Gear Box	Oil	3.5 L
 Gear Cover	Grease	4 Kg.

Note : Do not exceed the prescribed quantity

ATTENTION: The used oil must not be discharged into the natural environment, but consigned to bodies authorized for collection and subsequent disposal.

4.3. DAILY MAINTENANCE CHECK POINTS

- 4.3.1. Tightening of Fasteners.
- 4.3.2. Lubrication of Cardan Shaft joints (See the booklet supplied by the Cardan shaft manufacturer).
- 4.3.3. Gearbox Oil Level.
- 4.3.4. Cleaning of the Rotor.
- 4.3.5. Grease Level in lateral (Side) gears

- 4.3.6. Lubrication of Grease points.
- 4.3.7. Leakages of Oil/Grease
- 4.3.8. Blades – Broken/Worn Out/Bend
- 4.3.9. Any Damages
- 4.3.10. Any Cracks

4.4. PARKING :

Comply with the following instructions in order to ensure that the machine remains stable when released from the tractor:

- 4.4.1. Position the parking stand as shown in the figure 12
- 4.4.2. If the machine has a safety ram, position the pin as shown in the figure (1 Fig. 12).
- 4.4.3. Rest the drive line on the relative support.

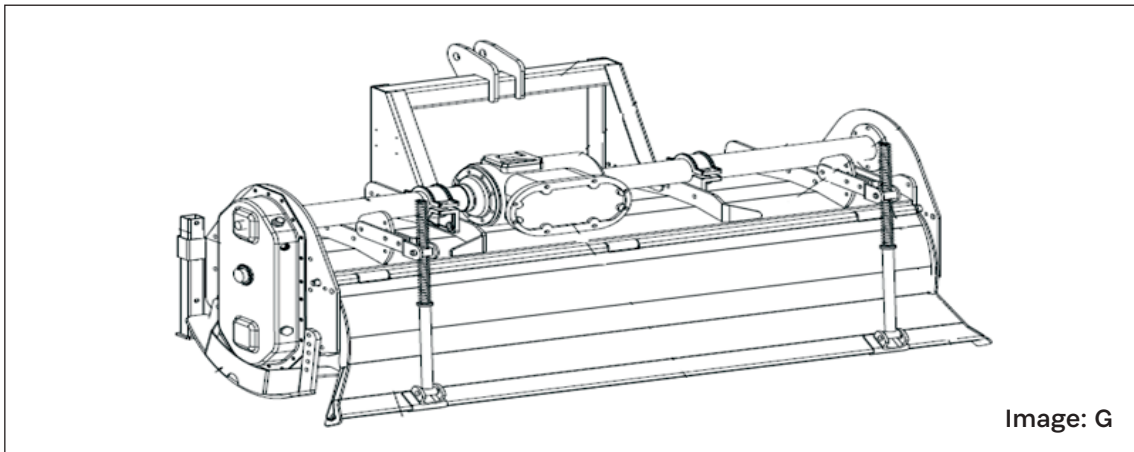

Image: G

4.5. STORAGE

- 4.5.1. Proceed in the following way at the end of the season or if the machine is to remain unused for a long period of time:
- 4.5.2. Wash the machine and dry it. Make sure that all fertilizer and chemical products have been removed.
- 4.5.3. Carefully check the implement and replace any damaged or worn parts.
- 4.5.4. Fully clamp all screws and bolts, particularly the ones that fix the tines.
- 4.5.5. Thoroughly grease the implement and protect it with a plastic sheet. Store it in a dry place. It is advisable to proceed with the following inspections before the machine is set at work again:
- 4.5.6. Check the oil levels in the gearbox and transmission unit. Top up if necessary.
- 4.5.7. Check the greasing points and add grease if required.
- 4.5.8. Check all bolts and tighten them if necessary.
- 4.5.9. Careful compliance with these instructions will be all to the advantage of the user who will be sure to use an implement in perfect conditions when work begins again.

The laws of the country where the machine is used, and particularly anti-pollution laws, must be observed if the machine should be scrapped. Remember that the Manufacturer is always at your disposal for any assistance or spare parts as may be required.

Sr. No.	Trouble	Possible Causes	Remedy
1.	Cardan Shaft Shear pin shears off	Overload due to hard/heavy soil.	Reduce depth of tilling.
		Overload due to High speed of machine.	Reduce the working speed with the help of Change Gears.
		Overload due to sudden obstacle	Passover the stony ground with implement lifted.
		Overload due to Stones/ Foreign material in the field.	Remove Stones/ Foreign material from the field.
		Overload due to Wet Soil.	Reduce machine rpm & Open the bonnet.
		Blockage of Wet Soil in the rotor blades.	If blades are worn out & bent replace them with new. Open the bonnet during working in wet soil.
		Incorrect Shear Pin Bolt	Use M10x1.5x65L with Class 10.9, Half threaded Shear bolt in Cardan shaft.
		Failure of transmission parts.	Check with trained service personnel & replace with genuine parts.
2.	Breakage of Blade (s)	Obstacle in the soil.	Passover the stony ground with implement lifted.
		Stoned Field.	Remove Stones/ Foreign material from the field.
		Loose Blades	Position & Fix blades with Torque wrench at 140 Nm.
		Worn out Hoes/Blades.	Replace with new genuine Hoes/Blades.
		Poor quality of blades	Replace with new genuine Hoes/Blades.
3.	Unusual noise in the gearbox	Low oil level	Top up with recommended oil.
		If the problem continues, contact Dealer.	
4.	Leakage of Lubricants from Gearbox or Side Gear	Loose joints	Tighten Fasteners properly.
		Damage to Gasket/Oil seals	Replace the Gasket/Oil seals.
		If the problem continues, contact Dealer.	
5.	Overheating of the rotor bearing housings.	Insufficient grease in the bearing	Clean the bearing, lubricate with fresh grease.
		Failure of Bearing.	Replace with recommended bearing.
		Excessive preloading of bearings.	Loosen the bearing setting nut (KM series special Nut).
		If the problem continues, contact Dealer.	
6.	Knocking in the PTO joint.	High inclination of Cardan Shaft with PTO shaft of tractor (near or above 30 Degree).	Reduce the angle by adjusting the height of the central linkage point of the tractor.

Sr. No.	Trouble	Possible Causes	Remedy
7.	Excessive noise	Loose joints.	Check all joints & tighten properly.
8.	Excessive Vibration	Loose Fasteners	Tighten Fasteners properly.
		Play in 3P Hitch Hole & Pin.	Check 3P Hitch & Pin for proper clearance, correct/replace accordingly.
		Worn out Hoes/Blades.	Replace the worn out Hoes/Blades by new.
		Residues or deposits in the Hoes/Blades or on the rotor	Clean the residue.
		If the problem continues, contact Dealer.	
9.	Poor Pulverization	Bonnet is more open	Set bonnet to an appropriate position
		Machine is not properly aligned/set w.r.t. Land & Tractor	Refer manual for machine setting/consult the service personnel.
		Low rotor speed.	Increase machine speed by change gears in respect of land. Ensure tractor PTO is at rated RPM.
		Worn out/Bend Blades.	Replace with new genuine Hoes/Blades.
10.	Excess Load on Tractor	Wet Soil	Reduce machine speed.
		High Tillage depth	Use appropriate depth in respect of soil condition.
		Clogging of soil in rotor blades.	Worn Out & bend blades are to be replaced by new genuine blades.
		Incorrect orientation of blades on rotor.	Refer machine manual.
		Oversize of Machine in respect of tractor.	Use right machine size as recommended.
		Hard Soil	Use appropriate depth in respect of soil condition.
		Clogging of soil in rotor & mainframe.	Open bonnet.
		If the problem continues, contact Dealer.	
11.	Clogging of Soil in rotor blades	Worn out & Bend Blades	Worn Out & bend blades are to be replaced by new genuine blades.
12.	Clogging of soil in rotor	Wet Soil	Open bonnet.

6.1 UNIVATOR KMW H SERIES Model: KMW 1500 H, KMW 1600 H, KMW 1800 H, KMW 2100 H

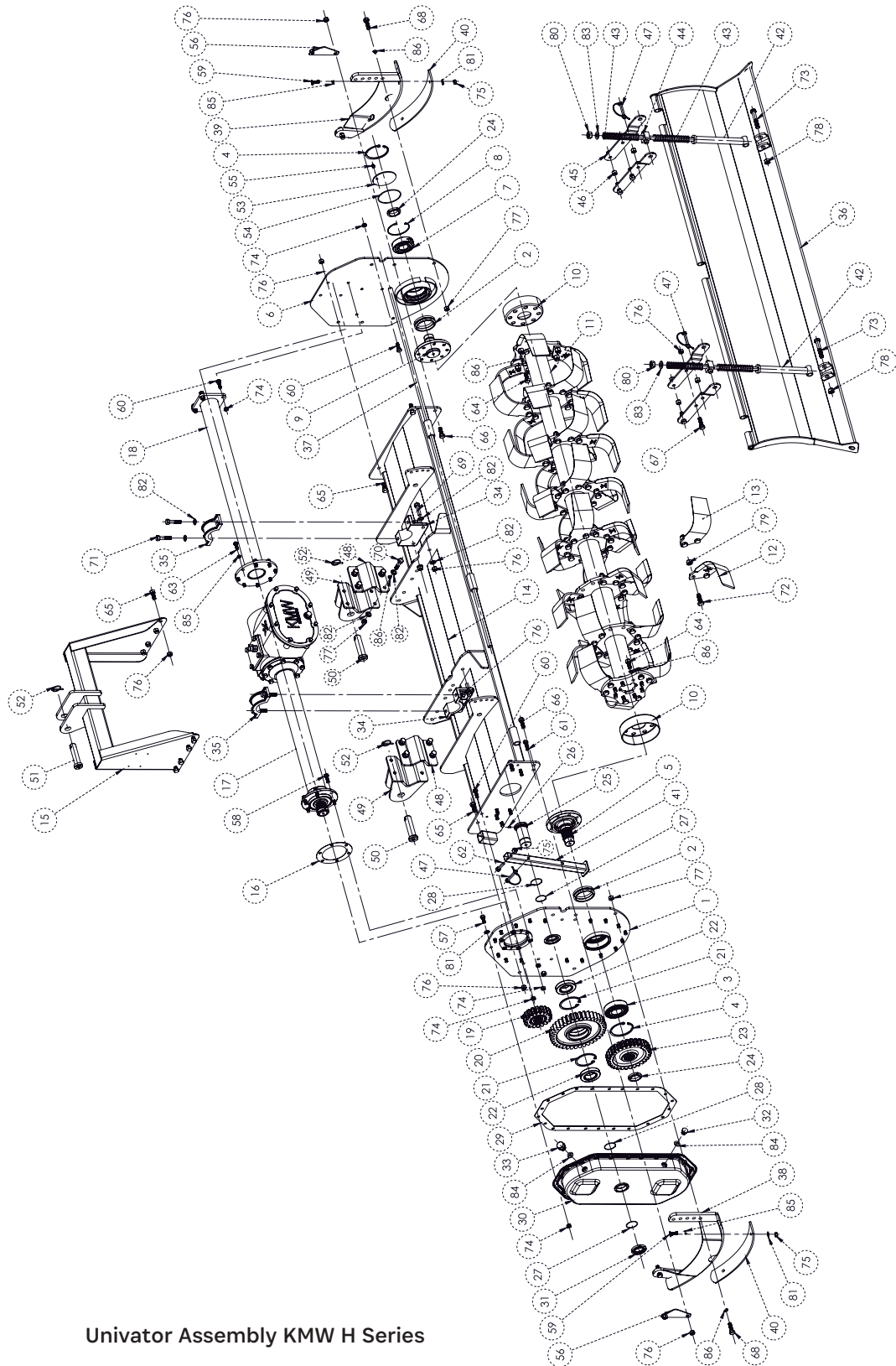

Univator Assembly KMW H Series

UNIVATOR ASSEMBLY: KMW H SERIES

S. No.	PART NO	Description	KMW 1200 H	KMW 1500 H	KMW 1600 H	KMW 1800 H	KMW 2100 H
1	M12.1200.002.0.00	Assembling GS Side Plate CE 1200	1	0	0	0	0
1	M15.1500.140.0.00	Assembling GS Side Plate CE	0	1	1	1	1
2	M15.1500.081.0.00	Mechanical Face Seal	2	2	2	2	2
3	M15.1500.082.0.00	Bearing 6309	1	1	1	1	1
4	M15.1500.901.0.00	Circlip Type -B ,100x3t	2	2	2	2	2
5	M15.1500.003.0.00	Rotor Drive Shaft CM	1	1	1	1	1
6	M15.1500.020.0.00	Assembling OS Side Plate CE	1	1	1	1	1
7	M15.1500.084.0.00	Bearing 6308	1	1	1	1	1
8	M15.1500.911.0.00	Circlip Type -B ,90x3t	1	1	1	1	1
9	M15.1500.005.0.00	Rotor Driven Shaft CM	1	1	1	1	1
10	M15.1500.107.0.00	Dust Protection Cap CM	2	2	2	2	2
11	M12.1200.003.0.00	Assembling Rotor CE 1200	1	0	0	0	0
11	M15.1500.030.0.00	Assembling Rotor CX 1500	0	1	0	0	0
11	M16.1600.001.0.00	Assembling Rotor CX 1600	0	0	1	0	0
11	M18.1800.030.0.00	Assembling Rotor CX 1800	0	0	0	1	0
11	M21.0901.011.0.00	Assembling Rotor CX 2100	0	0	0	0	1
12	M15.1500.085.0.00	RV BLADE L 80-14.5X57 RH with Logo Kirloskar	15	18	18	21	24
13	M15.1500.086.0.00	RV BLADE L 80-14.5X57 LH with Logo Kirloskar	15	18	18	21	24
14	M12.1200.004.0.00	Assembling Mainframe CE 1200	1	0	0	0	0
14	M15.1500.040.0.00	Assembling Mainframe CE 1500	0	1	0	0	0
14	M16.1600.021.0.00	Assembling Mainframe CE 1600	0	0	1	0	0
14	M15.1500.040.0.00	Assembling Mainframe CE 1800	0	0	0	1	0
14	M15.1500.040.0.00	Assembling Mainframe CE 2100	0	0	0	0	1
15	M15.1500.150.0.00	Assembling Top 3P Hitch CE	1	1	1	1	1
16	M15.1500.087.0.00	Gasket for Jackshaft CM	1	1	1	1	1
17	M12.1200.005.0.00	Gearbox & Jackshaft Assy CM 1300 (GB-011J-X4=632)	1	0	0	0	0
17	M15.1500.006.0.00	Gearbox & Jackshaft Assy CM 1500 (GB-011J-X4=704.5)	0	1	0	0	0
17	M16.1600.002.0.00	Gearbox & Jackshaft Assy CM 1600 (GB-011J-X4=756.5)	0	0	1	0	0
17	M18.1800.060.0.00	Gearbox & Jackshaft Assy CM 1800 (GB-011J-X4=854.5)	0	0	0	1	0
17	M21.0901.012.0.00	Gearbox & Jackshaft Assy CM 2100 (GB-011J-X4=1004.5)	0	0	0	0	1
18	M12.1200.006.0.00	Assembling Reinforce For Gear box CM 1200 (GB-011J-X4=632)	1	0	0	0	0
18	M15.1500.213.0.00	Assembling Reinforce For Gear box CM 1500 (GB-011J-X4=704.5)	0	1	0	0	0

UNIVATOR ASSEMBLY: KMW H SERIES

S. No.	PART NO	Description	KMW 1200 H	KMW 1500 H	KMW 1600 H	KMW 1800 H	KMW 2100 H
18	M16.1600.003.0.00	Assembling Reinforce For Gear box CM 1600 (GB-011J-X4=756.5)	0	0	1	0	0
18	M18.1800.155.0.00	Assembling Reinforce For Gear box CM 1800 (GB-011J-X4=854.5)	0	0	0	1	0
18	M21.0901.013.0.00	Assembling Reinforce For Gear box CM 2100 (GB-011J-X4=1004.5)	0	0	0	0	1
19	M15.1500.008.0.00	Top Gear Z 18 CM	1	1	1	1	1
20	M18.1800.006.0.00	Central Gear Z 38 CM 30209	1	1	1	1	1
21	M15.1500.911.0.00	Circlip Type -B ,85x3t	2	2	2	2	2
22	M15.1500.088.0.00	Bearing 30209	2	2	2	2	2
23	M15.1500.007.0.00	Bottom Gear Z30 CM	1	1	1	1	1
24	M15.1500.902.0.00	Lock nut KM 8	2	2	2	2	2
25	M15.1500.043.0.00	Central Gear Pin CM 30209	1	1	1	1	1
26	M15.1500.231.0.00	Key Pin For Central Gear Pin CM	1	1	1	1	1
27	M15.1500.232.0.00	O-Ring ID 42 mm x OD 46 mm	2	2	2	2	2
28	M15.1500.093.0.00	O-Ring ID 45 mm x OD 49 mm	2	2	2	2	2
29	M15.1500.089.0.00	Gasket for Gear Cover CM	1	1	1	1	1
30	M15.1500.070.0.00	Assembling Gear Cover CM 30209	1	1	1	1	1
31	M15.1500.958.0.00	Lock nut KM 9	1	1	1	1	1
32	M15.1500.906.0.00	Plug Drain 1/2"	1	1	1	1	1
33	M15.1500.907.0.00	Plug Breather 1/2"	1	1	1	1	1
34	M18.1800.007.0.00	Bottom Clamp For Gearbox Support CM	2	2	2	2	2
35	M15.1500.015.0.00	Top Clamp For Gearbox Support CM	2	2	2	2	2
36	M12.1200.007.0.00	Assembling Bonnet BX 1200	1	0	0	0	0
36	M15.1500.080.0.00	Assembling Bonnet CM 1500	0	1	0	0	0
36	M16.1600.004.0.00	Assembling Bonnet CM 1600	0	0	1	0	0
36	M18.1800.090.0.00	Assembling Bonnet CM 1800	0	0	0	1	0
36	M21.0901.014.0.00	Assembling Bonnet CM 2100	0	0	0	0	1
37	M12.1200.021.0.00	Bonnet Hinge Rod CM 1200	1	0	0	0	0
37	M15.1500.016.0.00	Bonnet Hinge Rod CM 1500	0	1	0	0	0
37	M16.1600.022.0.00	Bonnet Hinge Rod CM 1600	0	0	1	0	0
37	M18.1800.009.0.00	Bonnet Hinge Rod CM 1800	0	0	0	1	0
37	M21.2301.405.0.00	Bonnet Hinge Rod CM 2100	0	0	0	0	1
38	M15.1500.090.0.00	Assembling GS Skid Sole CM	1	1	1	1	1
39	M15.1500.100.0.00	Assembling OS Skid Sole CM	1	1	1	1	1
40	M18.1800.080.0.00	Vice Skid CM	2	2	2	2	2
41	M15.1500.110.0.00	Assembling Parking Stand CM	1	1	1	1	1
42	M15.1500.120.0.00	Assembling Shock Absorber CE	2	2	2	2	2

UNIVATOR ASSEMBLY: KMW H SERIES

S. No.	PART NO	Description	KMW 1200 H	KMW 1500 H	KMW 1600 H	KMW 1800 H	KMW 2100 H
43	M15.1500.091.0.00	Spring For Shock Absorber CM	4	4	4	4	4
44	M15.1500.019.0.00	Junction For Shock Absorber CM	2	2	2	2	2
45	M15.1500.149.0.00	Arm For Bonnet Adjuster CM	4	4	4	4	4
46	M15.1500.151.0.00	Bush For Bonnet Adjustor Arm	4	4	4	4	4
47	M15.1500.018.0.00	Trailer Coupler Safety Pin 10 dia x 75L	3	3	3	3	3
48	M12.1200.008.0.00	V Clamp For Bottom 3P Hitch BM	2	0	0	0	0
48	M15.1500.152.0.00	V Clamp For Bottom 3P Hitch CM	0	2	2	2	2
49	M12.1200.009.0.00	Assembling Bottom 3P Hitch BM	2	0	0	0	0
49	M18.1800.140.0.00	Assembling Bottom 3P Hitch CM	0	2	2	2	2
50	M15.1500.021.0.00	Bottom Hitch Pin CM	2	2	2	2	2
51	M15.1500.011.0.00	Top Hitch Pin CM	1	1	1	1	1
52	M15.1500.909.0.00	Linch pin 8mm	3	3	3	3	3
53	M15.1500.092.0.00	Seal Cap CM	1	1	1	1	1
54	M15.1500.211.0.00	O-Ring ID 94mm X OD 99 mm	1	1	1	1	1
55	M15.1500.912.0.00	Grease Nipple 1/8" BSP	1	1	1	1	1
56	M15.1500.212.0.00	Patch 3 mm t for GS & OS Plate CM	2	2	2	2	2
57	M15.1500.913.0.00	Bolt M10x1.25X25L-Class 8.8, FT,Black Oxide	18	18	18	18	18
58	M15.1500.233.0.00	Bolt M10x1.25X30L-Class 8.8, FT,Black Oxide, TVS Make	6	6	6	6	6
59	M15.1500.959.0.00	Bolt, Carriage M10x1.25x 30L - Class 8.8, Black oxide/Zinc Plated	4	4	4	4	4
60	M15.1500.234.0.00	Bolt M10x1.25X30L-Class 8.8, FT,Black Oxide	9	9	9	9	9
61	M15.1500.959.0.00	Bolt M10x1.25x35L-Class 8.8, FT,Black Oxide	4	4	4	4	4
62	M15.1500.235.0.00	Bolt M10x1.25x40L-Class 8.8, HT,Black Oxide	1	1	1	1	1
63	M15.1500.914.0.00	Bolt M10x1.5X25L-Class 8.8, FT,Black Oxide	8	8	8	8	8
64	M15.1500.918.0.00	Bolt M12x1.25x30L-Class 8.8, FT,Black Oxide,TVS Make	16	16	16	16	16
65	M15.1500.918.0.00	Bolt M12x1.25x30L-Class 8.8, FT,Black Oxide	12	12	12	12	12
66	M15.1500.919.0.00	Bolt M12x1.25x35L- Class 8.8, FT,Black Oxide	4	4	4	4	4

UNIVATOR ASSEMBLY: KMW H SERIES

S. No.	PART NO	Description	KMW 1200 H	KMW 1500 H	KMW 1600 H	KMW 1800 H	KMW 2100 H
67	M15.1500.921.0.00	Bolt M12x1.25x40L-Class 8.8, FT,Zinc Plated	4	4	4	4	4
68	M15.1500.921.0.00	Bolt M12x1.25x40L- Class 8.8, FT,Black Oxide	4	4	4	4	4
69	M15.1500.925.0.00	Bolt M12x1.25x45L- Class 8.8, HT,Black Oxide	4	4	4	4	4
70	M15.1500.236.0.00	Bolt M12x1.25X50LClass 8.8, HT,Black Oxide	4	8	8	8	8
71	M15.1500.237.0.00	Bolt M12x1.25x55L-Class 8.8, HT,Black Oxide	4	4	4	4	4
72	M15.1500.926.0.00	Bolt M14x1.5x40L-Class 8.8, HT,Black Oxide	60	72	72	84	96
73	M15.1500.928.0.00	Bolt M14x1.5x80L-Class 8.8, HT,Zinc Plated	2	2	2	2	2
74	M15.1500.931.0.00	Nut M10X1.25 - Class 8, Torque Prevailing,Zinc Plated	33	37	37	37	37
75	M15.1500.238.0.00	Nut M10X1.25 - Class 8, Hex Nut	5	5	5	5	5
76	M15.1500.934.0.00	Nut M12 X1.25 - Class 8, Torque Prevailing,Zinc Plated	28	36	28	28	28
77	M15.1500.239.0.00	Nut M12X1.25 - Class 8, Hex Nut	8	12	12	12	12
78	M15.1500.936.0.00	Nut M14X1.5 - Class 8 , Nylock Insert, Zinc plated	2	2	2	2	2
79	M15.1500.936.0.00	Nut M14X1.5 - Class 8,Torque Prevailing, Zinc Plated	60	72	72	84	96
80	M15.1500.939.0.00	Nut M16 x2 - Class 8 with Nylock,Zinc Plated	2	2	2	2	2
81	M15.1500.941.0.00	Washer Plain M10X21x2t, Zinc plated	26	26	26	26	26
82	M15.1500.942.0.00	Washer Plain M12x24x2.3t, Zinc plated	20	28	28	28	28
83	M15.1500.944.0.00	Washer Plain M16x30x3.5t, Zinc plated	2	2	2	2	2
84	M15.1500.949.0.00	Washer Copper G 1/2	2	2	2	2	2
85	M18.1800.942.0.00	Washer Spring M10X17.5x2t, Black Oxide	12	12	12	12	12
86	M15.1500.961.0.00	Washer Spring M12X19.5x2.4t, Black Oxide	24	28	28	28	28
98	M18.1800.813.0.00	O & M Manual KMW	1	1	1	1	1
101	M18.1800.818.0.00	Ring Spanner 22/24	1	1	1	1	1
102	M18.1800.819.0.00	Ring Spanner 17/19	2	2	2	2	2
103	M18.1800.821.0.00	Flat Spanner22/24	1	1	1	1	1
104	M18.1800.822.0.00	Pouch For Tools	1	1	1	1	1

UNIVATOR ASSEMBLY: KMW H SERIES

S. No.	PART NO	Description	KMW 1200 H	KMW 1500 H	KMW 1600 H	KMW 1800 H	KMW 2100 H
105	M15.1501.041.0.00	Product Name Plate Kirloskar	1	1	1	1	1
106	M18.1800.945.0.00	Pop Rivets For Number Plate	4	4	4	4	4
107	M18.1800.142.0.00	Safety Label No.① 150X75	1	1	1	1	1
108	M18.1800.151.0.00	Safety Label No.② 150X75	1	1	1	1	1
109	M18.1800.146.0.00	Safety Label No.③ 150X75	1	1	1	1	1
110	M18.1800.827.0.00	Lubricants 145X60	1	1	1	1	1
111	M18.1800.145.0.00	KMW UNIVATOR 808X180	1	1	1	1	1
112	M18.1800.143.0.00	PTO rpm 540 70X60 / “ PTO rpm 1000" 70X60	1	1	1	1	1
114	M12.1200.022.0.00	1200 148X53	1	0	0	0	0
114	M15.1500.241.0.00	1500 148X53	0	1	0	0	0
114	M16.1600.023.0.00	1600 148X53	0	0	1	0	0
114	M18.1800.001.0.00	1800 148X53	0	0	0	1	0
114	M21.2301.411.0.00	2100 148X53	0	0	0	0	1
115	M12.1200.023.0.00	L 30 72x55	1	0	0	0	0
115	M15.1500.242.0.00	L 36 72x55	0	1	1	0	0
115	M18.1800.002.0.00	L 42 72x55	0	0	0	1	0
115	M21.2301.412.0.00	L 48 72x55	0	0	0	0	1
116	M15.1500.243.0.00	TEST OK Round 80	1	1	1	1	1

GEAR BOX ASSEMBLY KMW H SERIES

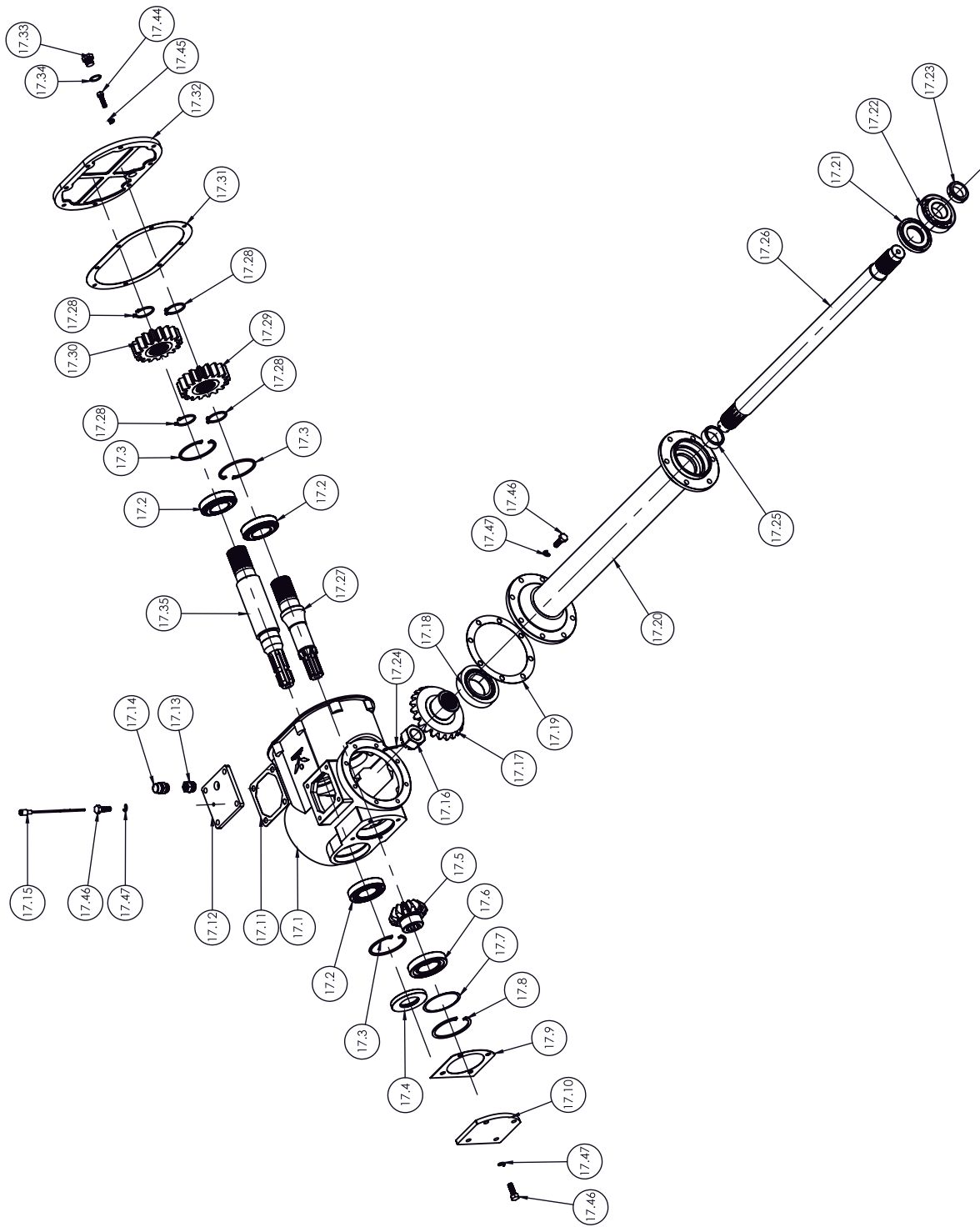

GEAR BOX ASSEMBLY KMW H SERIES

S. No.	PART NO	Description	KMW 1200 H	KMW 1500 H	KMW 1600 H	KMW 1800 H	KMW 2100 H
17.1	M15.1500.201.0.00	Gearbox Housing GB-011J	1	1	1	1	1
17.2	M15.1500.094.0.00	Bearing 30209	3	3	3	3	3
17.3	M15.1500.095.0.00	Circlip Type -B ,85x3t	3	3	3	3	3
17.4	M15.1500.169.0.00	Oil Seal 85x45x10	1	1	1	1	1
17.5	M15.1500.023.0.00	Bevel Pinion Z-14 For GB-011J	1	1	1	1	1
17.6	M15.1500.096.0.00	Bearing 30210	1	1	1	1	1
17.7	M15.1500.244.0.00	Shim For GB-011J	1	1	1	1	1
17.8	M15.1500.097.0.00	Circlip Type -B ,90x3t	1	1	1	1	1
17.9	M15.1500.098.0.00	Gasket For Front Cover GB-011J	1	1	1	1	1
17.1	M15.1500.202.0.00	Front Cover For GB-011J	1	1	1	1	1
17.11	M15.1500.099.0.00	Gasket For Top Cover GB-011J	1	1	1	1	1
17.12	M15.1500.203.0.00	Top Cover For GB-011J	1	1	1	1	1
17.13	M15.1500.951.0.00	Adapter Nipple	1	1	1	1	1
17.14	M15.1500.071.0.00	Breather Plug 3/8"	1	1	1	1	1
17.15	M15.1500.171.0.00	Dip Stick For GB-011J	1	1	1	1	1
17.16	M15.1500.952.0.00	Slotted Nut M30x1.5	1	1	1	1	1
17.17	M15.1500.024.0.00	Bevel Gear Z-22 For GB-011J	1	1	1	1	1
17.18	M15.1500.072.0.00	Bearing 32211	1	1	1	1	1
17.19	M15.1500.073.0.00	Gasket For Gearbox Conical Flange GB-011J	1	1	1	1	1
17.20	M12.1200.011.0.00	Assembling Jackshaft CM 1300 Machining (GB-011J-X4=632)	1	0	0	0	0
17.20	M15.1500.025.0.00	Assembling Jackshaft CM 1500 Machining (GB-011J-X4=704.5)	0	1	0	0	0
17.20	M16.1600.005.0.00	Assembling Jackshaft CM 1600 Machining (GB-011J-X4=756.5)	0	0	1	0	0
17.20	M18.1800.014.0.00	Assembling Jackshaft CM 1800 Machining (GB-011J-X4=854.5)	0	0	0	1	0
17.20	M21.0901.015.0.00	Assembling Jackshaft CM 2100 Machining (GB-011J-X4=1004.5)	0	0	0	0	1
17.21	M15.1500.074.0.00	Oil seal 80x40x10	1	1	1	1	1
17.22	M15.1500.075.0.00	Bearing 30308	1	1	1	1	1
17.23	M15.1500.903.0.00	Lock nut KM 7	1	1	1	1	1
17.24	M15.1500.953.0.00	Split pin 1/8"X55L	1	1	1	1	1
17.25	M15.1500.026.0.00	Spacer For Gearbox GB-011J	1	1	1	1	1
17.26	M12.1200.012.0.00	Transmission Shaft CM 1300 Machining (GB-011J-X4=632)	1	0	0	0	0
17.26	M15.1500.027.0.00	Transmission Shaft CM 1500 Machining (GB-011J-X4=704.5)	0	1	0	0	0

GEAR BOX ASSEMBLY KMW H SERIES

S. No.	PART NO	Description	KMW 1200 H	KMW 1500 H	KMW 1600 H	KMW 1800 H	KMW 2100 H
17.26	M16.1600.006.0.00	Transmission Shaft CM 1600 Machining (GB-011J-X4=756.5)	0	0	1	0	0
17.26	M18.1800.015.0.00	Transmission Shaft CM 1800 Machining (GB-011J-X4=854.5)	0	0	0	1	0
17.26	M21.0901.016.0.00	Transmission Shaft CM 2100 Machining (GB-011J-X4=1004.5)	0	0	0	0	1
17.27	M15.1500.028.0.00	Pinion Shaft For GB-011J	1	1	1	1	1
17.28	M15.1500.954.0.00	Circlip Type -A ,45x2.5t	4	4	4	4	4
17.29	M15.1500.036.0.00	Change Gear Z-17 For GB-011J	1	1	1	1	1
17.30	M15.1500.037.0.00	Change Gear Z-18 For GB-011J	1	1	1	1	1
17.31	M15.1500.076.0.00	Gasket For Back Cover GB-011J	1	1	1	1	1
17.32	M18.1800.204.0.00	Back Cover For GB-011J	1	1	1	1	1
17.33	M15.1500.906.0.00	Plug Drain 1/2"	1	1	1	1	1
17.34	M15.1500.949.0.00	Washer Copper G 1/2	1	1	1	1	1
17.35	M15.1500.031.0.00	PT.O Drive Shaft For GB-011J	1	1	1	1	1
17.36	M15.1500.033.0.00	Change Gear Z-13 For GB-011J	Optional				
17.37	M15.1500.034.0.00	Change Gear Z-14 For GB-011J	Optional				
17.38	M15.1500.035.0.00	Change Gear Z-15 For GB-011J	Optional				
17.39	M15.1500.032.0.00	Change Gear Z-16 For GB-011J	Optional				
17.4	M15.1500.029.0.00	Change Gear Z-19 For GB-011J	Optional				
17.41	M15.1500.038.0.00	Change Gear Z-20 For GB-011J	Optional				
17.42	M15.1500.039.0.00	Change Gear Z-21 For GB-011J	Optional				
17.43	M15.1500.041.0.00	Change Gear Z-22 For GB-011J	Optional				
17.44	M15.1500.957.0.00	Bolt M8X1.25X30L-Class 8.8,FT, Zinc Plated	8	8	8	8	8
17.45	M15.1500.956.0.00	Washer Spring M8X14x2t, Zinc Plated	8	8	8	8	8
17.46	M15.1500.955.0.00	Bolt M10X1.5X30L-Class 8.8, FT,Zinc Plated	16	16	16	16	16
17.47	M18.1800.942.0.00	Washer Spring M10X17.5x2t, Zinc Plated	16	16	16	16	16

6.3 UNIVATOR KMW L SERIES Model: KMW 1500 L, KMW 1600 L, KMW 1800 L

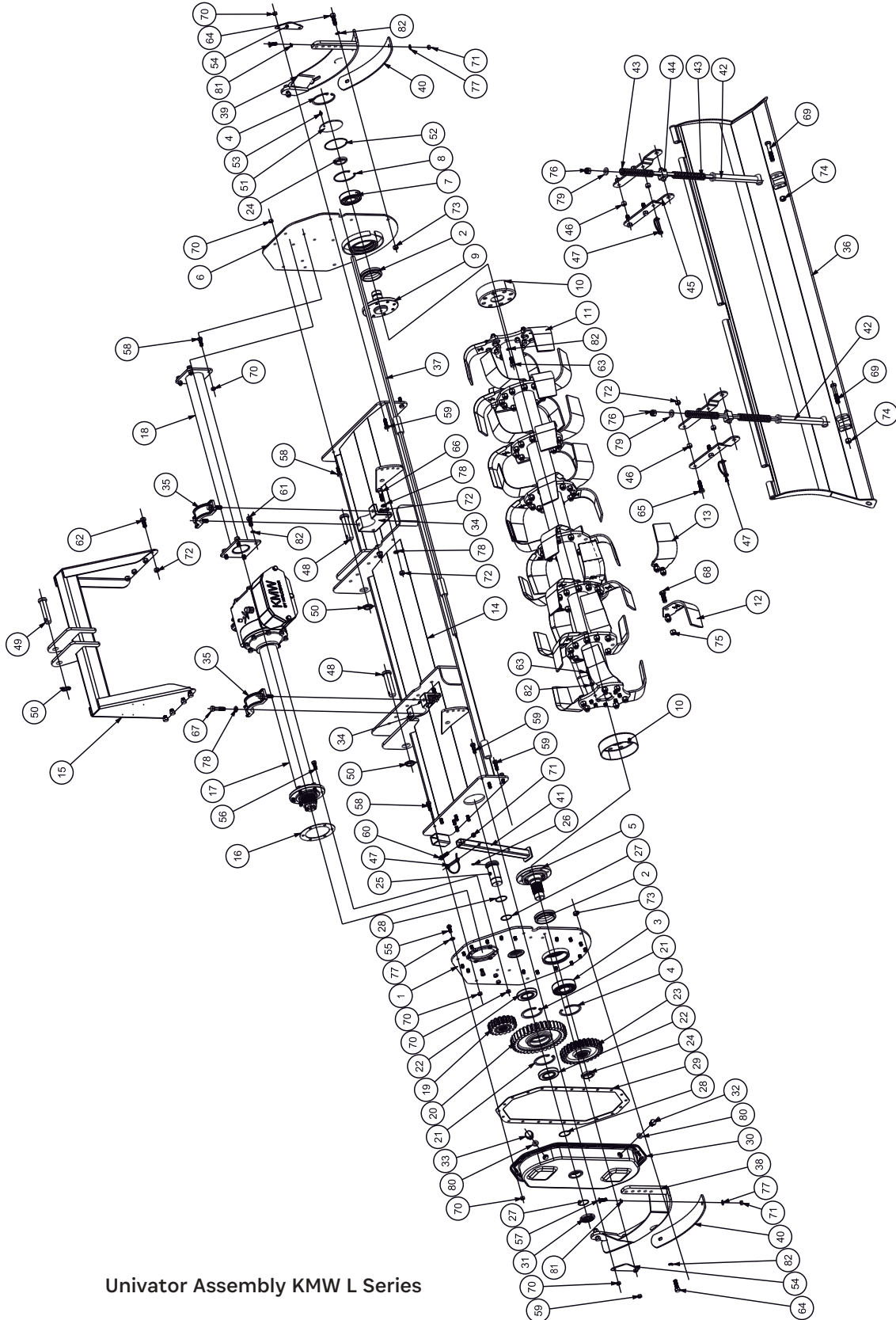

Univator Assembly KMW L Series

6.3 UNIVATOR KMW L SERIES Model: KMW 1500 L, KMW 1600 L, KMW 1800 L

S. No	PART NO	DESCRIPTION	KMW 1500 L	KMW 1600 L	KMW 1800 L
1	M15.CX00.022.0.00	Assembling GS Side Plate CX 1500 MS	1	1	1
2	M15.1500.081.0.00	Mechanical Face Seal	2	2	2
3	M15.1500.082.0.00	Bearing 6309	1	1	1
4	M15.1500.901.0.00	Circlip Type -B ,100x3t	2	2	2
5	M15.1500.003.0.00	Rotor Drive Shaft CM	1	1	1
6	M15.CX00.014.0.00	Assembling OS Side Plate CX	1	1	1
7	M15.1500.084.0.00	Bearing 6308	1	1	1
8	M15.1500.911.0.00	Circlip Type -B ,90x3t	1	1	1
9	M15.1500.005.0.00	Rotor Driven Shaft CM	1	1	1
10	M15.1500.107.0.00	Dust Protection Cap CM	2	2	2
11	M15.1500.030.0.00	Assembling Rotor CX 1500	1	0	0
11	M16.1600.001.0.00	Assembling Rotor CX 1600	0	1	0
11	M18.1800.030.0.00	Assembling Rotor CX 1800	0	0	1
12	M15.1500.085.0.00	RV BLADE L 80-14.5X57 RH with Logo Kirloskar	18	18	21
13	M15.1500.086.0.00	RV BLADE L 80-14.5X57 LH with Logo Kirloskar	18	18	21
14	M15.CX00.025.0.00	Assembling Mainframe CX 1500	1	0	0
14	M16.CX00.001.0.00	Assembling Mainframe CX 1600	0	1	0
14	M18.CX00.002.0.00	Assembling Mainframe CX 1800	0	0	1
15	M15.CX00.013.0.00	Assembling Top 3P Hitch CX	1	1	1
16	M15.CX00.036.0.00	Gasket for Jackshaft BM	1	1	1
17	M15.CX00.026.0.00	Gearbox & Jackshaft Assy CX1500 (RT020-X4=722.5)	1	1	0
17	M18.CX00.003.0.00	Gearbox & Jackshaft Assy CX1800 (RT020-X4=912.5)	0		01
18	M15.CX00.027.0.00	Assembling Reinforce For Gearbox CX1500 (RT020-X4=722.5)	X4=722.5)	1	00
18	M16.CX00.002.0.00	Assembling Reinforce For Gearbox CX1600 (RT020-X4=722.5)	0	1	0
18	M18.CX00.004.0.00	Assembling Reinforce For Gearbox CX1800 (RT020-X4=912.5)	0	0	1
19	M15.CX00.008.0.00	Top Gear Z 18 CX	1	1	1
20	M18.1800.006.0.00	Central Gear Z 38 CM 30209	1	1	1
21	M15.1500.911.0.00	Circlip Type -B ,90x3t	2	2	2
22	M15.1500.088.0.00	Bearing 30209	2	2	2
23	M15.CX00.007.0.00	Bottom Gear Z28 GbCX002	1	1	1
24	M15.1500.902.0.00	Lock nut KM 8	2	2	2
25	M15.1500.043.0.00	Central Gear Pin CM 30209	1	1	1
26	M15.1500.231.0.00	Key Pin For Central Gear Pin CM	1	1	1

6.3 UNIVATOR KMW L SERIES Model: KMW 1500 L, KMW 1600 L, KMW 1800 L

S. No	PART NO	DESCRIPTION	KMW 1500 L	KMW 1600 L	KMW 1800 L
27	M15.1500.232.0.00	O-Ring ID 42 mm x OD 46 mm	2	2	2
28	M15.1500.093.0.00	O-Ring ID 45 mm x OD 49 mm	2	2	2
29	M15.1500.089.0.00	Gasket for Gear Cover CM	1	1	1
30	M15.1500.070.0.00	Assembling Gear Cover CM 30209	1	1	1
31	M15.1500.958.0.00	Lock nut KM 9	1	1	1
32	M15.1500.906.0.00	Plug Drain 1/2"	1	1	1
33	M15.1500.907.0.00	Plug Breather 1/2"	1	1	1
34	M18.1800.007.0.00	Bottom Clamp For Gearbox Support CM	2	2	2
35	M15.1500.015.0.00	Top Clamp For Gearbox Support CM	2	2	2
36	M15.CX00.033.0.00	Assembling Bonnet CX1500	1	0	0
36	M16.CX00.003.0.00	Assembling Bonnet CX1600	0	1	0
36	M18.CX00.001.0.00	Assembling Bonnet CXE 1800	0	0	1
37	M15.1500.016.0.00	Bonnet Hinge Rod CM 1500	1	0	0
37	M16.1600.022.0.00	Bonnet Hinge Rod CM 1600	0	1	0
37	M18.1800.009.0.00	Bonnet Hinge Rod CM 1800	0	0	1
38	M15.1500.090.0.00	Assembling GS Skid Sole CM	1	1	1
39	M15.1500.100.0.00	Assembling OS Skid Sole CM	1	1	1
40	M18.1800.080.0.00	Vice Skid CM	2	2	2
41	M15.1500.110.0.00	Assembling Parking Stand CM	1	1	1
42	M15.1500.120.0.00	Assembling Shock Absorber CE	2	2	2
43	M15.1500.091.0.00	Spring For Shock Absorber CM	4	4	4
44	M15.1500.019.0.00	Junction For Shock Absorber CM	2	2	2
45	M15.1500.149.0.00	Arm For Bonnet Adjuster CM	4	4	4
46	M15.1500.151.0.00	Bush For Bonnet Adjuster Arm	4	4	4
47	M15.1500.018.0.00	Trailer Coupler Safety Pin 10 dia x 75L	3	3	3
48	M15.1500.021.0.00	Bottom Hitch Pin CM	2	2	2
49	M15.1500.011.0.00	Top Hitch Pin CM	1	1	1
50	M15.1500.909.0.00	Linch pin 8mm	3	3	3
51	M15.1500.092.0.00	Seal Cap CM	1	1	1
52	M15.1500.211.0.00	O-Ring ID 94mm X OD 99 mm	1	1	1
53	M15.1500.912.0.00	Grease Nipple 1/8" BSP	1	1	1
54	M15.CX00.015.0.00	Patch 3 mm t For GS & OS Plate CXE	2	2	2
55	M15.1500.913.0.00	Bolt M10x1.25X25L-Class 8.8,FT, Black Oxide	18	18	18
56	M15.1500.233.0.00	Bolt M10x1.25X30L-Class 8.8,FT, Black Oxide,TVS Make	6	6	6
57	M15.1500.959.0.00	Bolt, Carriage M10x1.25x 30L -Class 8.8, Black oxide	4	4	4
58	M15.1500.234.0.00	Bolt M10x1.25X30L-Class 8.8,FT, Black Oxide	13	13	13

6.3 UNIVATOR KMW L SERIES Model: KMW 1500 L, KMW 1600 L, KMW 1800 L

S. No	PART NO	DESCRIPTION	KMW 1500 L	KMW 1600 L	KMW 1800 L
59	M15.1500.959.0.00	Bolt, Carriage M10x1.25x 30L -Class 8.8, Black oxide	8	8	8
60	M15.1500.235.0.00	Bolt M10x1.25x40L-Class 8.8,HT, Black Oxide	1	1	1
61	M15.CX00.017.0.00	Bolt M12x1.25x25L-Class 8.8,FT, Black Oxide	4	4	4
62	M15.1500.918.0.00	Bolt M12x1.25x30L-Class 8.8,FT, Black Oxide	8	8	8
63	M15.1500.918.0.00	Bolt M12x1.25x30L-Class 8.8,FT, Black Oxide	16	16	16
64	M15.1500.921.0.00	Bolt M12x1.25x40L- Class 8.8,FT, Black Oxide	4	4	4
65	M15.1500.921.0.00	Bolt M12x1.25x40L- Class 8.8,FT, Black Oxide	4	4	4
66	M15.1500.925.0.00	Bolt M12x1.25x45L- Class 8.8,HT, Black Oxide	4	4	4
67	M15.1500.237.0.00	Bolt M12x1.25x55L-Class 8.8,HT, Black Oxide	4	4	4
68	M15.1500.926.0.00	Bolt M14x1.5x40L-Class 8.8,HT, Black Oxide	72	72	84
69	M15.1500.928.0.00	Bolt M14x1.5x80L-Class 8.8,HT, Zinc Plated	2	2	2
70	M15.1500.931.0.00	Nut M10X1.25 - Class 8, Torque Prevailing, Zinc Plated	37	37	45
71	M15.1500.238.0.00	Nut M10X1.25 - Class 8, Hex Nut	5	5	5
72	M15.1500.934.0.00	Nut M12 X1.25 - Class 8, Torque Prevailing,Zinc Plated	20	20	20
73	M15.1500.239.0.00	Nut M12X1.25 - Class 8, Hex Nut	4	4	4
74	M15.1500.936.0.00	Nut M14X1.5 - Class 8 , Nylock Insert, Zinc plated	2	2	2
75	M15.1500.936.0.00	Nut M14X1.5 - Class 8 , Nylock Insert, Zinc plated	72	72	84
76	M15.1500.939.0.00	Nut M16 x2 - Class 8 with Nylock, Zinc Plated	2	2	2
77	M15.1500.941.0.00	Washer Plain M10X21x2t, Zinc plated	26	26	26
78	M15.1500.942.0.00	Washer Plain M12x24x2.3t,Zinc plated	12	12	12
79	M15.1500.944.0.00	Washer Plain M16x30x3t, Zinc plated	2	2	2
80	M15.1500.949.0.00	Washer Copper G 1/2	2	2	2
81	M18.1800.942.0.00	Washer Spring M10X17.5x2t, Black Oxide	4	4	4
82	M15.1500.961.0.00	Washer Spring M12X19.5x2.4t,Black Oxide	24	24	24

6.3 UNIVATOR KMW L SERIES Model: KMW 1500 L, KMW 1600 L, KMW 1800 L

S. No	PART NO	DESCRIPTION	KMW 1500 L	KMW 1600 L	KMW 1800 L
94	M18.1800.813.0.00	O & M Manual KMW	1	1	1
97	M18.1800.818.0.00	Ring Spanner 22/24	1	1	1
98	M18.1800.819.0.00	Ring Spanner 17/19	2	2	2
99	M18.1800.821.0.00	Flat Spanner 22/24	1	1	1
100	M18.1800.822.0.00	Pouch For Tools	1	1	1
101	M15.1501.041.0.00	Product Name Plate Kirloskar	1	1	1
102	M18.1800.945.0.00	Pop Rivets For Number Plate	4	4	4
103	M18.1800.142.0.00	"Safety Label No.①" 150X75	1	1	1
104	M18.1800.151.0.00	"Safety Label No.②" 150X75	1	1	1
105	M18.1800.146.0.00	"Safety Label No.③" 150X75	1	1	1
106	M18.1800.827.0.00	"Lubricants" 145X60	1	1	1
107	M18.1800.145.0.00	"KMW UNIVATOR" 808X180	1	1	1
108	M15.CX00.016.0.00	"Rotor Speed Chart RT 020 Gearbox For C Series" 80X117	1	1	1
109	M18.1800.143.0.00	"PTO rpm 540" 70X60 / "PTO rpm 1000" 70X60	1	1	1
111	M15.1500.241.0.00	"1500" 148X53	1	0	0
111	M16.1600.023.0.00	"1600" 148X53	0	1	0
111	M18.1800.001.0.00	"1800" 148X53	0	0	1
112	M15.1500.242.0.00	"L 36" 72x55	1	1	0
112	M18.1800.002.0.00	"L 42" 72x55	0	0	1
113	M15.1500.243.0.00	"TEST OK" Round 80	1	1	1

GEAR BOX ASSEMBLY KMW L SERIES

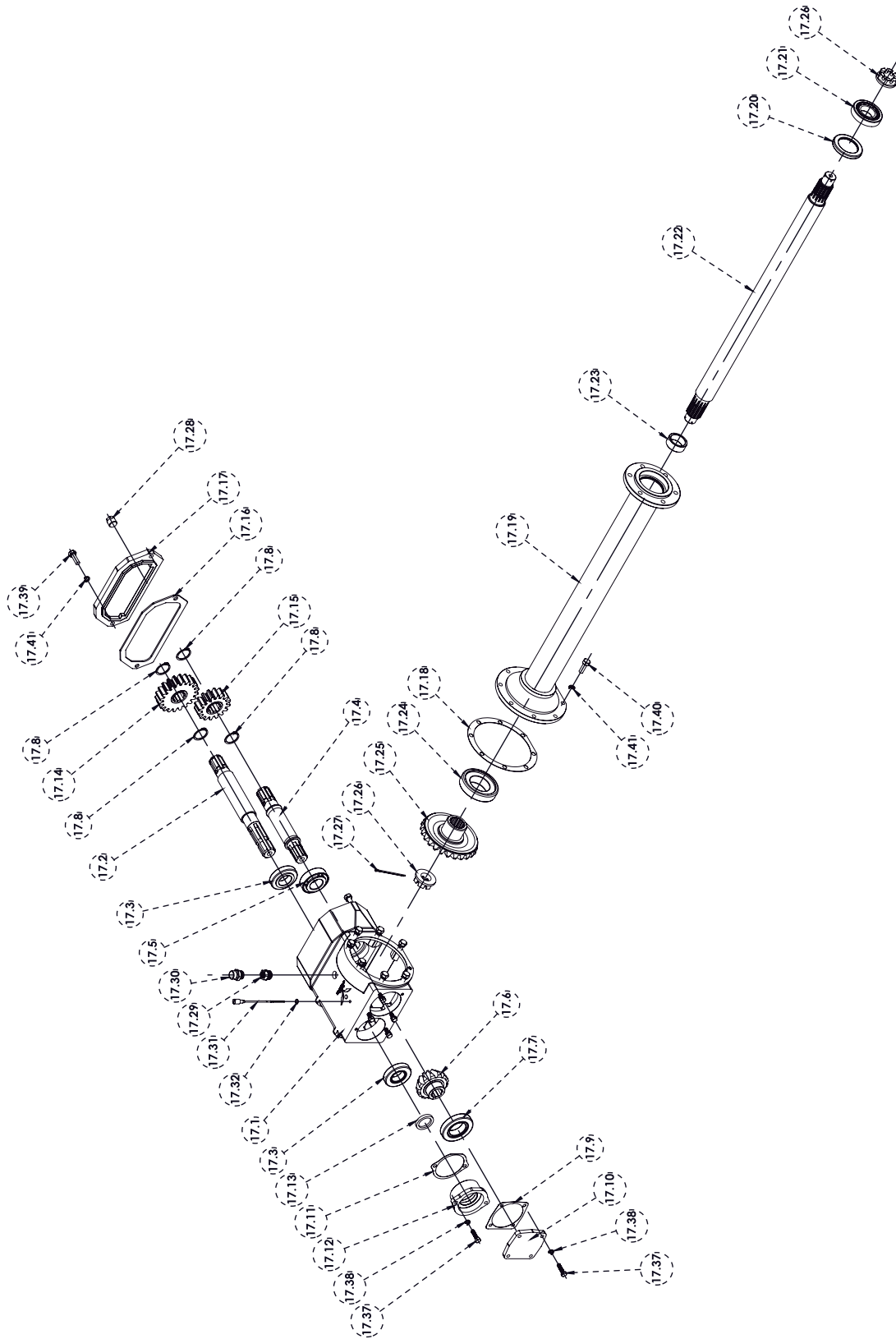

GEAR BOX ASSEMBLY KMW L SERIES

S. No	PART NO	DESCRIPTION	KMW 1500 L	KMW 1600 L	KMW 1800 L
17.1	M15.CX00.003.0.00	Gearbox Housing RT-020	1	1	1
17.2	M15.CX00.031.0.00	P. T. O. Drive Shaft For RT020 (2-Speed)	1	1	1
17.3	M15.CX00.094.0.00	Bearing 30207	2	2	2
17.4	M15.CX00.028.0.00	Pinion Shaft For RT020 (2-Speed)	1	1	1
17.5	M15.CX00.042.0.00	Bearing 32207 B	1	1	1
17.6	M15.CX00.023.0.00	Bevel pinion Z-13 For RT020	1	1	1
17.7	M15.CX00.096.0.00	Bearing 30209	1	1	1
17.8	M15.CX00.018.0.00	Circlip Type -A ,35x1.5t	4	4	4
17.9	M15.CX00.037.0.00	Gasket Front Cover For RT020	2	2	2
17.10	M15.CX00.004.0.00	Front Cover For RT020	1	1	1
17.11	M15.CX00.038.0.00	Gasket For Bearing Housing RT020	2	2	2
17.12	M15.CX00.043.0.00	Bearing Housing For Bearing 30207	1	1	1
17.13	M15.CX00.169.0.00	Oil Seal 35X47X7	1	1	1
17.14	M15.CX00.029.0.00	Change Gear Z-20 For RT020	1	1	1
17.15	M15.CX00.032.0.00	Change Gear Z-16 For RT020	1	1	1
17.16	M15.CX00.076.0.00	Gasket For Back Cover RT020	1	1	1
17.17	M15.CX00.009.0.00	Back Cover For RT020 (2- Speed)	1	1	1
17.18	M15.CX00.073.0.00	Gasket For Gearbox Conical			
		Flange RT020	1	1	2
17.19	M15.CX00.034.0.00	Assembling Jackshaft CX 1500			
		Machining (RT020-X4=722.5)	1	1	0
17.19	M18.CX00.005.0.00	Assembling Jackshaft CX 1800			
		Machining (RT020-X4=912.5)	0	0	1
17.20	M15.CX00.039.0.00	Oil Seal 80X55X10	1	1	1
17.21	M15.CX00.041.0.00	Bearing 30208	1	1	1
17.22	M15.CX00.035.0.00	Transmission Shaft CX 1500 (RT020-X4=722.5)	1	1	0
17.22	M18.CX00.006.0.00	Transmission Shaft CX 1800 (RT020-X4=912.5)	0	0	1
17.23	M15.CX00.001.0.00	Spacer For RT020	1	1	1
17.24	M15.1500.072.0.00	Bearing 32211	1	1	1
17.25	M15.CX00.024.0.00	Bevel Gear Z-25 For RT020	1	1	1
17.26	M15.CX00.019.0.00	Slotted Nut M30X1.5X20 With Flange	2	2	2
17.27	M15.1500.952.0.00	Split pin 1/8"X55L	1	1	1
17.28	M15.1500.906.0.00	Plug Drain 1/2"	1	1	1
17.29	M15.1500.951.0.00	Adapter Nipple	1	1	1
17.30	M15.1500.071.0.00	Breather Plug 3/8"	1	1	1
17.31	M15.CX00.002.0.00	Dip Stick For RT020	1	1	1
17.32	M15.CX00.021.0.00	Washer For Dip Stick	1	1	1
17.33	M15.CX00.011.0.00	Change Gear Z-14 For RT020	Optional	Optional	Optional

GEAR BOX ASSEMBLY KMW L SERIES

S. No	PART NO	DESCRIPTION	KMW 1500 L	KMW 1600 L	KMW 1800 L
17.34	M15.CX00.005.0.00	Change Gear Z-17 For RT020	Optional	Optional	Optional
17.35	M15.CX00.006.0.00	Change Gear Z-19 For RT020	Optional	Optional	Optional
17.36	M15.CX00.012.0.00	Change Gear Z-22 For RT020	Optional	Optional	Optional
17.37	M15.1500.957.0.00	Bolt M8x1.25X30L-Class 8.8, FT,Zinc Plated	6	6	6
17.38	M15.1500.956.0.00	Washer Spring M8X14x2t, Zinc Plated	6	6	6
17.39	M15.1500.234.0.00	Bolt M10x1.25X30L-Class 8.8, FT,Black Oxide	2	2	2
17.40	M15.1500.955.0.00	Bolt M10x1.5X30L-Class 8.8, FT, Zinc Plated	8	8	8
17.41	M18.1800.942.0.00	Washer Spring M10X17.5x2t, Black Oxide	10	10	10

6.5 CARDAN SHAFT ASSEMBLY

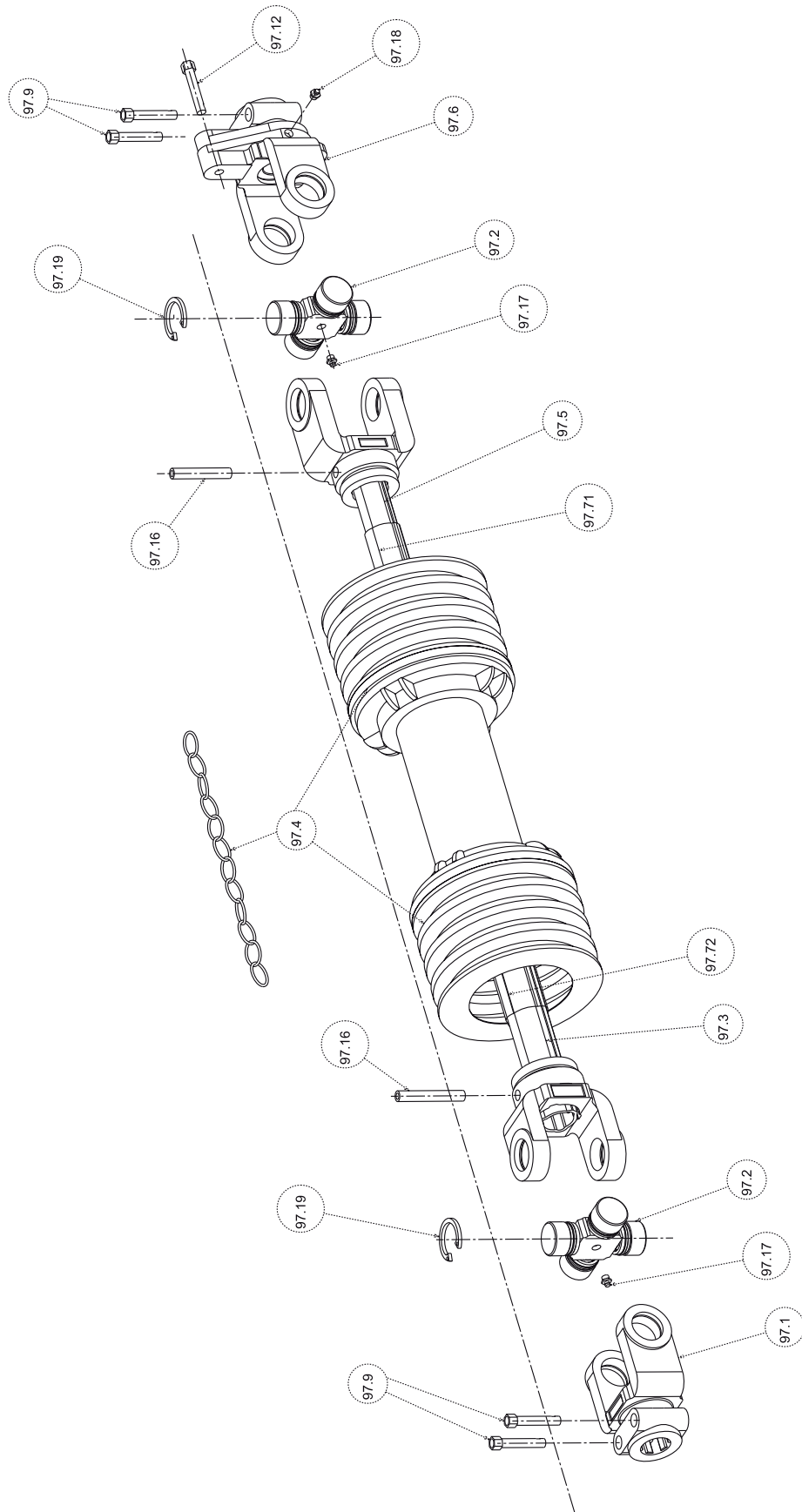

6.5 CARDAN SHAFT ASSEMBLY

S. No	PART NO	DESCRIPTION	Qty
	M18.1800.816.0.00	Cardan Shaft (Complete Assembly)	
	M15.1500.181.0.00	Cardan Shaft 21 SPL (Complete Assembly)	
97.1	M18.1800.098.0.00	Spring Yoke for TT-38 Model	1
97.2	M15.1500.180.0.00	U.J.Cross - For TT38 Model	2
97.3	M18.1800.031.0.00	Qtr. Shaft : Simple Yoke & Outer Tube for TT38 Model	1
97.4	M18.1800.106.0.00	Guard Covers for TT38 Model	1
97.5	M18.1800.958.0.00	Qtr. Shaft : Simple Yoke & Inner Tube for TT38 Model	1
97.6	M18.1800.959.0.00	Shear Yoke for BS-38 & TT-38 Model	1
97.7	M18.1800.961.0.00	Metal Triangular Profile tubes - Inner & Outer for TT38 Model	1
97.71	M18.1800.962.0.00	Metal Triangular Profile tube Inner for TT38 Model	1
97.72	M18.1800.963.0.00	Metal Triangular Profile tube Outer for TT38 Model	1
97.8	M18.1800.964.0.00	Quick Release Pin : For 21 Splined yoke	4
97.9	M18.1800.965.0.00	Quick Release Pin : For 6 Splined yoke	4
97.1	M18.1800.966.0.00	Simple Yoke for TT38 Model with Dowel Pin for Inner tube	1
97.11	M18.1800.967.0.00	Simple Yoke for TT38 Model with Dowel Pin for Outer tube	1
97.12	M18.1800.968.0.00	Shear Bolt with Nut:10mm , 65L,10.9 Grade, Half threaded	1
97.13	M18.1800.969.0.00	Shear Bolt with Nut : 10mm , 65 L ,8.8 Grade,Full threaded	1
97.14	M18.1800.971.0.00	Shear Bolt with Nut : 10mm , 65 L ,8.8 Grade, Half threaded	1
97.15	M18.1800.972.0.00	Shear Bolt with Nut :12mm, 65L,10.9 Grade, Half threaded	1
97.16	M18.1800.973.0.00	Dowel Pin Set - 82 mm X1 Nos. & 72 mm X1 Nos. -12mm DiaX 2.5mm t	2
97.17	M18.1800.974.0.00	Grease Nipple - 45 Degree	2
97.18	M18.1800.975.0.00	Grease Nipple - 90 Degree	1
97.19	M18.1800.976.0.00	Circlip 38x1.5t	8

6.6 COULTER WHEEL ASSEMBLY*

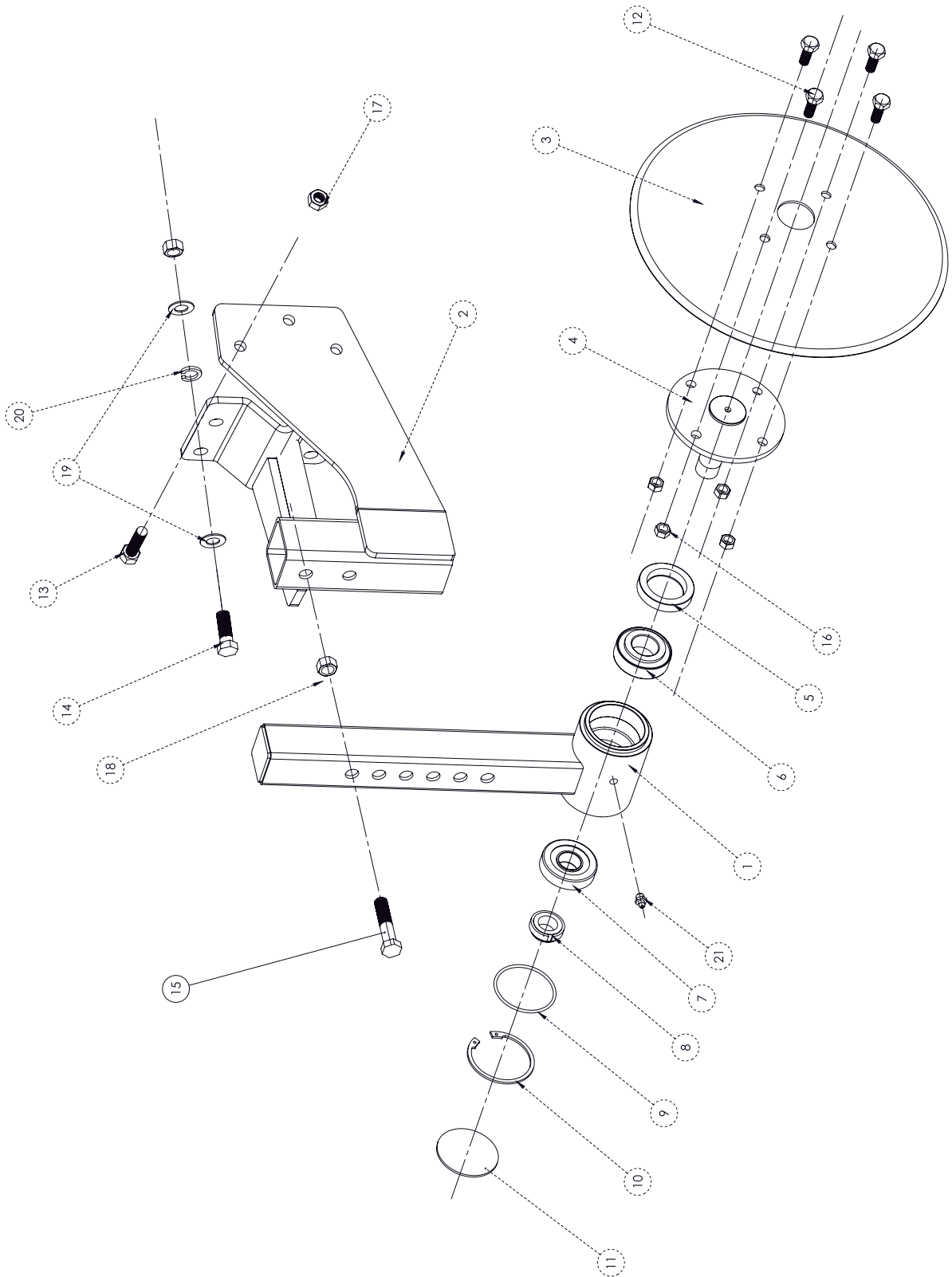

6.6 COULTER WHEEL ASSEMBLY*

S. No	PART NO	DESCRIPTION	Qty
	M18.1800.205.0.00	COULTER WHEEL (Complete Assembly)	
1	M15.1500.245.0.00	Assembling Bearing Housing With Guide Pipe OS	1
2	M15.1500.246.0.00	Coulter Wheel Guide Assy OS	1
3	M15.1500.247.0.00	Coulter Wheel	1
4	M15.1500.248.0.00	Coulter Wheel Mounting Shaft	1
5	M15.1500.249.0.00	Oil Seal 42x62x12	1
6	M15.1500.251.0.00	Bearing 32206	1
7	M15.1500.252.0.00	Bearing 30305	1
8	M15.1500.905.0.00	Lock Nut KM 5	1
9	M15.1500.253.0.00	O ring ID 64x3	1
10	M15.1500.254.0.00	Internal Circlip 75x2.5	1
11	M15.1500.255.0.00	Housing End Plate	1
12	M15.1500.913.0.00	Bolt M10x1.25X25L-Class 8.8,FT,Black Oxide	4
13	M15.1500.925.0.00	Bolt M12x1.25x45L-Class 8.8,FT,Black Oxide	3
14	M15.1500.926.0.00	Bolt M14x1.5x40L-Class 8.8,HT,Black Oxide	4
15	M15.1500.927.0.00	Bolt M14x1.5X65L-Class 8.8,HT,Black Oxide	1
16	M15.1500.933.0.00	Nut M10X1.25 - Class 8, Torque Prevailing,Zinc Plated	4
17	M15.1500.934.0.00	Nut M12 X1.25 - Class 8, Torque Prevailing,Zinc Plated	3
18	M15.1500.936.0.00	Nut M14X1.5 - Class 8 , Nylock Insert, Zinc plated	5
19	M15.1500.943.0.00	Washer Plain M14x27x3t, Zinc plated	8
20	M18.1800.943.0.00	Washer Spring M14X23.40x3t,Black Oxide.	5
21	M15.1500.912.0.00	Grease Nipple 1/8" BSP	1

*Coulter Wheel is Not Part of Standard Rotary Tiller and has to be purchased by Customer Separately as per requirement

7.0

WARRANTY REGISTRATION CARD

Univator Warranty Card				S.N	Customer Copy
Model :		Machine		Invoice No.	
Machine No :		Application Code		Invoice Date	
Tractor Model & HP:		Warranty Start Date		Warranty End Date	
Customer Details :					
Name:					
Village:				Pin:	
City:				District:	
State:				Country:	
Mobile I Mail ID:					
I agree to abide by the condition printed on Warranty Card and Operations & Maintenance Manual.					
Customer Signature			Dealer's Seal & Signature		
IMPORTANT: Quote Machine No., Invoice No. & Date and Delivery date in all y our correspondence. Any alteration in this Warranty Card renders the warranty null and void.					

Univator Warranty Card				S.N	Customer Copy
Model :		Machine		Invoice No.	
Machine No :		Application Code		Invoice Date	
Tractor Model & HP:		Warranty Start Date		Warranty End Date	
Customer Details :					
Name:					
Village:				Pin:	
City:				District:	
State:				Country:	
Mobile I Mail ID:					
I agree to abide by the condition printed on Warranty Card and Operations & Maintenance Manual.					
Customer Signature			Dealer's Seal & Signature		
IMPORTANT: Quote Machine No., Invoice No. & Date and Delivery date in all y our correspondence. Any alteration in this Warranty Card renders the warranty null and void.					

Univator Warranty Card				S.N	Customer Copy
Model :		Machine		Invoice No.	
Machine No :		Application Code		Invoice Date	
Tractor Model & HP:		Warranty Start Date		Warranty End Date	
Customer Details :					
Name:					
Village:				Pin:	
City:				District:	
State:				Country:	
Mobile I Mail ID:					
I agree to abide by the condition printed on Warranty Card and Operations & Maintenance Manual.					
Customer Signature			Dealer's Seal & Signature		
IMPORTANT: Quote Machine No., Invoice No. & Date and Delivery date in all y our correspondence. Any alteration in this Warranty Card renders the warranty null and void.					

UNIVATOR PRE DELIVERY INSPECTION CARD					Dealer Copy	
Dealership Name:			Dealer Code :			
Machine Application Code and Serial No :			Machine Model:			
Invoice No and Invoice Date:			Installation & PDI Date:			
S. No	Parameters	Specification	Measuring Equipment	Observations	Remarks	
Dimensional Parameters						
1	Distance between Bracket	As per Customer Requirement	Measuring Tape			
2	Bracket Pin & Linch Pin	Availability	Visual			
3	Working Width	As per Model	Measuring Tape			
4	Blade Model	As per Model	Visual			
5	Blade Tighten (M14x1.5)	155 Nm	Torque Wrench			
Aesthetic Parameters						
6	Oil Level in Gear Box	Oil Level	Dip Stick / Visual			
7	Grease Level in Gear Cover	Grease Present	Visual (Manually)			
8	No Leakage from Gear Box	Visual	Visual			
9	Pipe Support	Uniform Clamping	Visual			
10	Breather / Cork in Gear Box & Drive Cover tank	Availability	Visual			
11	Gear Box Bolts Tight	Check	Torque Wrench			
12	Shock Abs . Support Patta as per Model	Check	Torque Wrench			
13	Support Pipe Stand	Check	Torque Wrench			
14	No. of Blades	As per Model	Visual			
15	Rotary Model	As per Model / Customer Requirement	Visual			
16	Door Spring and Pin	Availability	Visual			
17	Door Assembly Lock Pin	Availability	Visual			
18	Door Rod Tight	Check	Visual			
19	Oil Level in oil cup	Oil Level	Visual (Manually)			
20	Copper Washer for Oil level of Gear Box	Availability	Visual			
21	LOGO	Gear Box logo KMW	Visual			
22	Visual Inspection / Appearance	Free from Oil Leakage, Rust etc in Machine	Visual			
Machine Testing Details						
23	Noise and Vibration	Free from abnormal Noise in Gear Box	Manual / Visual			
24	Noise and Vibration	Free from abnormal Noise in Gear drive cover	Manual / Visual			
25	Rotavator Testing with Tractor	Proper function	Manual / Visual			
Sticker Details						
26	Sticker Details	As per Model	Visual			
Accessories And Fitting						
27	CS Skid with Vice Skid	Availability	Visual			
28	OS Skid with Vice Skid	Availability	Visual			
29	Input Shaft Cover	Availability	Visual			
30	PTO / Cardan Shaft as per Model	Availability	Visual			
31	Shock Abs . Assembly as per Model	Availability	Visual			
32	Tool Kit and Manual	Availability	Visual			
Signature of Customer			Signature of Dealer/Dealer Technician			

UNIVATOR PRE DELIVERY INSPECTION CARD					Company Copy
Dealership Name:			Dealer Code :		
Machine Application Code and Serial No :			Machine Model:		
Invoice No and Invoice Date:			Installation & PDI Date:		
S. No	Parameters	Specification	Measuring Equipment	Observations	Remarks
Dimensional Parameters					
1	Distance between Bracket	As per Customer Requirement	Measuring Tape		
2	Bracket Pin & Linch Pin	Availability	Visual		
3	Working Width	As per Model	Measuring Tape		
4	Blade Model	As per Model	Visual		
5	Blade Tighten (M14x1.5)	155 Nm	Torque Wrench		
Aesthetic Parameters					
6	Oil Level in Gear Box	Oil Level	Dip Stick / Visual		
7	Grease Level in Gear Cover	Grease Present	Visual (Manually)		
8	No Leakage from Gear Box	Visual	Visual		
9	Pipe Support	Uniform Clamping	Visual		
10	Breather / Cork in Gear Box & Drive Cover tank	Availability	Visual		
11	Gear Box Bolts Tight	Check	Torque Wrench		
12	Shock Abs . Support Patta as per Model	Check	Torque Wrench		
13	Support Pipe Stand	Check	Torque Wrench		
14	No. of Blades	As per Model	Visual		
15	Rotary Model	As per Model / Customer Requirement	Visual		
16	Door Spring and Pin	Availability	Visual		
17	Door Assembly Lock Pin	Availability	Visual		
18	Door Rod Tight	Check	Visual		
19	Oil Level in oil cup	Oil Level	Visual (Manually)		
20	Copper Washer for Oil level of Gear Box	Availability	Visual		
21	LOGO	Gear Box logo KMW	Visual		
22	Visual Inspection / Appearance	Free from Oil Leakage, Rust etc in Machine	Visual		
Machine Testing Details					
23	Noise and Vibration	Free from abnormal Noise in Gear Box	Manual / Visual		
24	Noise and Vibration	Free from abnormal Noise in Gear drive cover	Manual / Visual		
25	Rotavator Testing with Tractor	Proper function	Manual / Visual		
Sticker Details					
26	Sticker Details	As per Model	Visual		
Accessories And Fitting					
27	CS Skid with Vice Skid	Availability	Visual		
28	OS Skid with Vice Skid	Availability	Visual		
29	Input Shaft Cover	Availability	Visual		
30	PTO / Cardan Shaft as per Model	Availability	Visual		
31	Shock Abs . Assembly as per Model	Availability	Visual		
32	Tool Kit and Manual	Availability	Visual		
Signature of Customer			Signature of Dealer/Dealer Technician		

UNIVATOR INSTALLATION WORKSHEET			Dealer Copy
Customer Name :		Application Code and Serial No:	
Residential Address :		Installation Date:	
Mobile No :		Installation Location:	
Dealership Name :		Dealer Code:	
Dealer Address		Invoice No and Date:	
Functions Explained & Demonstrated:		Yes/ No:--	
(Please Put ✓ Mark In Box After Explanation & Demonstration)			
Accessories Provided			
Operator Manual		Tool Kit	Remarks
Warranty Card Filled		Cardan Shaft	Remarks
Know your Machine			
Location of Serial No Plate and Machine No		Location of Skid & Skid Sole	Location for Checking Grease and Oil
Location of Off Side Plate		Location of Breather	Location of Grease Nipples.
Location of Gear Cover Side Plate		Location of Parking Stand	Location of Gear Box Drain Plug
Correct Direction of Blades		Location of 3 Point Hitch	Location of Side Gears Drain Plug
Location of Bonnet Adjustor			
How to Do?			
How to check Oil and Grease Level.		How to Fill Oil in gear box.	How to Fill grease in Side gear box.
How to couple Implement with Tractor		How to adjust working depth.	How to drain Oil & Grease from gearbox.
How to decouple implement from Tractor		How to Adjust Cardan Shaft	How to change the Rotor Speed.
Signature of Customer		Signature of Dealer/Dealer Technician	

UNIVATOR INSTALLATION WORKSHEET				Company Copy
Customer Name :		Application Code and Serial No:		
Residential Address :		Installation Date:		
Mobile No :		Installation Location:		
Dealership Name :		Dealer Code:		
Dealer Address		Invoice No and Date:		
Functions Explained & Demonstrated:		Yes/ No:--		
(Please Put ✓ Mark In Box After Explanation & Demonstration)				
Accessories Provided				
Operator Manual		Tool Kit		Remarks
Warranty Card Filled		Cardan Shaft		Remarks
Know your Machine				
Location of Serial No Plate and Machine No		Location of Skid & Skid Sole		Location for Checking Grease and Oil
Location of Off Side Plate		Location of Breather		Location of Grease Nipples.
Location of Gear Cover Side Plate		Location of Parking Stand		Location of Gear Box Drain Plug
Correct Direction of Blades		Location of 3 Point Hitch		Location of Side Gears Drain Plug
Location of Bonnet Adjustor				
How to Do?				
How to check Oil and Grease Level.		How to Fill Oil in gear box.		How to Fill grease in Side gear box.
How to couple Implement with Tractor		How to adjust working depth.		How to drain Oil & Grease from gearbox.
How to decouple implement from Tractor		How to Adjust Cardan Shaft		How to change the Rotor Speed.
Signature of Customer			Signature of Dealer/Dealer Technician	



KIRLOSKAR OIL ENGINES LTD.

A Kirloskar Group Company

Regd. Office: Laxmanrao Kirloskar Road, Khadki, Pune 411003, India
Toll Free No. +9120-2581 3208 | www.kmwagri.com | info@kirloskar.com



Enriching Lives